

**GESAMT
KATALOG**

solida[®]
GERMANY

Beat the hammer



**EINSTECKWERKZEUGE
FÜR PROFIS.**

www.solida-werk.com

hydraulictools

pneumatictools

electrotools

Wir haben eine felsenfeste Überzeugung: Unsere Kunden vertrauen auf uns, weil wir der Hersteller sind. Und das ist gut so. Denn nur als Hersteller sind wir in der Lage, schnell und mit höchstem Qualitätsanspruch zu agieren. Unser Ohr ist immer bei Ihnen, am Markt und an den Anforderungen unserer Verwender.

Schon seit 1946 ist das unser Ziel. Damals gab es bereits Pneumatik-Hämmer, die ersten elektrischen Hämmer ebenso. Ihren Siegeszug traten sie allerdings erst in den 1960ern an, die Hydraulik-Welt öffnete sich ca. 10 Jahre später. Damit ist SOLIDA der Hersteller von Einsteckwerkzeugen der ersten Stunde. Ein Erfahrungsschatz, der überzeugt.

Wir wollen das Beste und daher ist unser Standort von Anbeginn Remscheid. Das Herz der Werkzeugfertigung, weltbekannt als Stadt des Werkzeuges, steht für zeitgemäße Technologie, Innovation und Fachleute mit hochkarätigem Know-how gleichermaßen.

Rund 70 Spezialisten bringen Tag für Tag ihr Wissen in unserem Produktionswerk in Remscheid ein. Sie steuern die Produktion mit unserer Schmiedetechnologie, die in der Branche einzigartig ist.

Wir machen keine Kompromisse, denn unser Anspruch ist eine absolut überzeugende Qualität, die im Einsatz zeigt, was sie kann, überall und global für unsere Kunden: für Profis.

WIR SIND DIE MACHER!

Sie und Ihre Kunden sind die Profis im Einsatz.
Wir sind die Profis in der Produktion, mit
einem Know-how, das weltweit seines-
gleichen sucht.

Arbeiten Sie mit unserem
Katalog oder lernen Sie die
SOLIDA-Welt online kennen.

Sie finden uns und unsere
Produkte hier:

www.solida-werk.com

Der SOLIDA-Film in 3 Minuten:



EINER FÜR ALLES!

Ihre Aufgabe ist für uns das Ziel: Stemmen, Aufbrechen, Zerkleinern, Abbauen, Einschlagen und vieles mehr. Hier bieten wir Lösungen für die unterschiedlichsten Praxisaufgaben. Was immer Sie wollen: SOLIDA bietet Ihnen das optimale Einsteckwerkzeug für die Praxis.

Wir sind Ihr antriebsunabhängiger Partner.

Ganz gleich, ob Sie Ihr Einsteckwerkzeug für den Hydraulikhammer, den pneumatisch oder elektrisch betriebenen Hammer benötigen, SOLIDA ist immer Ihr Partner für das Profi-Werkzeug.

Wir sind Ihr hammerunabhängiger Partner.

Für die meisten Hammertypen dieser Welt gibt es SOLIDA-Werkzeuge. Ganz gleich, wer der Hersteller Ihres Hammers ist, wir liefern Ihr Wunschwerkzeug mit dem passenden Einsteckende.

Bei allem, was wir tun, denken wir zuerst an die beste Arbeitsseite für Ihren Praxiseinsatz. Lernen Sie die Varianten-Vielfalt von SOLIDA kennen.



Beat the hammer

hydraulictools

Für den Einsatz im Steinbruch, im Fundament-, Graben- und Straßenbau produzieren wir Großmeißel und Einsteckwerkzeuge, präzise auf die Übertragung der Energie durch die Schlagwerke abgestimmt. Haltekeilnuten mit gefrästen Öltaschen zur optimalen Schmierung und mit optimalem Sitz in der Meißelbuchse für schwierigste Einsatzbedingungen.

pneumatictools

Vorwiegend für den Einsatz im Straßenbau, Hoch- und Tiefbau, Abbruch, im Steinmetzhandwerk, im Bergbau oder in der Gießereitechnik. Die unterschiedlichen Varianten haben einen präzisen Sitz im Hammerfutter und übertragen die Energie optimal mit enormer Standfestigkeit.

electrotools

Einsteckwerkzeuge und Bohrer für die verschiedensten, elektrisch angetriebenen Abbruch- und Bohrhämmer. Die vielen Arbeitsseiten machen den Unterschied: Mit ihnen lassen sich die Aufgaben in der Praxis schneller und damit hochwirtschaftlich umsetzen.



INHALT

Der Hersteller	2 – 3
Einer für Alles	4 – 5
Inhalt	6 – 7
Qualität „Made in Germany“	8 – 9
Vielfalt	10 – 11
Eigene Produktion/Innovation	12 – 13
Zahlen, Daten, Fakten	14 – 15
OEM Qualität	16 – 17
Service	18

hydraulictools

	19
Die Hydraulic-Story	20 – 21
Index/Überblick Arbeitsseiten	22 – 24
Produkte	25 – 126

pneumatictools

	127
Die Pneumatic-Story	128 – 129
Überblick Arbeitsseiten/Einsteckenden	130 – 131
Produkte	132 – 148

electrotools

	149
Die Electro-Story	150 – 151
Überblick Arbeitsseiten	152 – 153
Überblick Einsteckenden	154
Produkte Einsteckwerkzeuge	155 – 172
Produkte Bohrer	173 – 181

FAKT BEI SOLIDA: QUALITÄT MADE IN GERMANY

FAKT 1:

Was Sie spüren, ist Qualität, bereits wenn Sie ein SOLIDA-Produkt in den Händen halten.

- Wir haben eine eigene Werkstoffentwicklung und verwenden einzigartige Hochleistungsstähle
- SOLIDA-Produkte sind durch Spezial-Härteverfahren optimal auf ihren jeweiligen Einsatzzweck abgestimmt
- Die modernste Schmiedetechnologie steht für perfektionierte Arbeitsseiten
- Der präzise Schliff garantiert den perfekten Einsatz

FAKT 2:

Was zählt, ist der Einsatz – das überzeugt jeden Profi.

- Perfekte Einsteckenden übertragen die Energie jedes einzelnen Schlages optimal
- Unsere Produkte haben höchste Standzeiten, sie sind enorm zäh und mit höchster Dauerfestigkeit
- Das heißt: längerer Einsatz, denn SOLIDA ist extrem hoch verschleißfest
- Weniger Werkzeugwechsel, weniger Rüstzeit
- Für jedes Kraft-Frequenz-Verhältnis
- Haltekeilnuten mit gefrästen Öltaschen zur optimalen Schmierung in der Hydraulik
- Hochwirtschaftlich, kosteneffizient

FAKT 3:

Was begeistert, ist Service und Auswahl.

- Unterschiedlichste Arbeitsseiten für Universal- und Spezial-einsätze
- Optimierte Spezialgeometrien, geschmiedet für besten Arbeitserfolg
- Verschiedenste Einsteckenden für alle gängigen Hammertypen
- Großlager - just in time, termin-treu und hochflexibel
- Über 5.000 Varianten
- Kundenbezogene Fertigung, schnell und genau nach Wunsch
- Zertifizierte Qualität





Qualitätsmanagement



Arbeitsschutz



Umweltschutz



Energiemanagement

FAKT 4:
Was dahinter steht, ist unser Management-System.

Qualität kommt nicht von ungefähr. SOLIDA steht für ein integriertes Management-System. Selbstverständlich ist unser Qualitätsmanagement-System nach DIN EN ISO 9001 zertifiziert, und damit sind alle Produktionsabläufe, Technologien, Materialien und das Team höchster Qualität verpflichtet.

Als ganzheitlich denkendes Unternehmen ist uns auch der Umweltschutz wichtig, wir gehen wirtschaftlich, effizient und umweltschonend mit allen Ressourcen um. Unser Umweltmanagementsystem ist nach DIN EN ISO 14001 eingerichtet und in unserem Energiemanagementsystem nach DIN EN ISO 50001 werden unsere energetischen Ziele in regelmäßigen Audits geprüft. Schon immer ist uns die Sicherheit unserer Mitarbeiter besonders wichtig, unser Arbeitsschutzmanagement nach OHSAS 18001 ist daher Bestandteil des betrieblichen Alltags.



SAG MIR, WAS DU MACHST, UND ICH SAG DIR, WAS DU BRAUCHST!



Die Kraft des Hammers optimal umsetzen. Das ist Ihr Ziel, das ist unser Ziel.

Daher haben wir für die vielen unterschiedlichen Aufgaben, bei denen der Einsatz eines Hammers gefragt ist, genau die richtigen Einsteckwerkzeuge entwickelt.

Sie haben alle so einiges gemeinsam: Sie setzen die Kraft des Hammers optimal um, sie machen die Arbeit leichter, sie machen die Arbeit schneller. Dadurch ist jede unserer Arbeitsseiten hochwirtschaftlich.

Ob Sie im Steinbruch Knäpper sprengen wollen, im Straßenbau auf extrem widerstandsfähigen Asphalt stoßen, einen Blitzableiter installieren, poröse Fugen im Mauerwerk oder einen PVC-Boden entfernen möchten: SOLIDA bietet für jedes Ihrer Vorhaben die Werkzeuglösung.





Mehr als

50

ARBEITSSEITEN

WAS IST DAS OPTIMALE?

Unsere Spezialisten beraten
Sie schnell und einfach am
Telefon. Einsatzzweck nennen
und wir zeigen Ihnen das
optimale Einsteckwerkzeug:

T +49 2191 3715-0



UNSERE STÄRKE IST PRODUKTION UND INNOVATION

**Man sagt uns nach, wir seien
perfektionistisch veranlagt.
Das mag stimmen, als Hersteller
können wir einfach nicht anders.**

Für unsere Entwickler ist bereits das Material eine Wissenschaft für sich: Wir haben eine eigene Werkstoffentwicklung und verwenden einzigartige Hochleistungsstähle. Den härtesten Einsatz zu bestehen, ist unser Ziel. Daher sind SOLIDA-Produkte durch Spezial-Härteverfahren optimal auf ihren jeweiligen Einsatzzweck abgestimmt.

Wo gearbeitet wird, spielt die Musik. Daher ist die modernste Schmiedetechnologie gerade gut genug, um die perfektionierten Arbeitsseiten der SOLIDA-Werkzeuge zu fertigen.

Der präzise Schliff formt die Kanten für den Dauer-Einsatz draußen in der Praxis.

Aus der Praxis für die Praxis.

Für uns müssen Innovationen handfest sein, denn Sie müssen sich bei Ihnen im Markt auch handfest bewähren. Aus diesem Grund analysieren wir alle Ideen und Prototypen in unserem firmeneigenen Testareal.

Neu im Programm ist der Spitzmeißel mit Sprengwirkung.

Die Geometrie seiner Spitze ist nicht pyramidal, sondern spiralförmig gefertigt. Damit dringt der Meißel schneller ins Material und erhöht den Abtrag. Der entstehende Staub wird wirkungsvoll abtransportiert, und der Meißel setzt sich nicht fest. Es ist der neue Allrounder mit maximierter Abtragsleistung für die unterschiedlichsten Aufbrucharbeiten und das Erstellen von Öffnungen und Durchbrüchen in Beton, Mauerwerk aus Ziegel und vielen weiteren Werkstoffen. Idealerweise auch für den Einsatz zum Abbau von losem Gestein.





solida

ZAHLEN, DATEN, FAKTEN

Für diejenigen, die schnelle Informationen bevorzugen, finden Sie SOLIDA anhand der wichtigsten Zahlen in einem Schnellüberblick dargestellt.

Seit dem Gründungsjahr 1946 ist SOLIDA ein unabhängiges Familienunternehmen. Unsere Einsteckwerkzeuge begeistern seither die Kunden weltweit. Dafür gibt es zwei Gründe: Maschinen und Menschen. Da hinter jeder Produktions-Technologie Menschen stehen, sind für SOLIDA die Mitarbeiter sehr wichtig. Sie sind es, die nicht nur für die Kundenzufriedenheit, sondern auch hinter Innovationen und der SOLIDA-Qualität stehen.



70 JAHRE



ca. 70 MITARBEITER



5.000 VARIANTEN

FÜR ca. **9.000** HAMMERTYPEN

PASSEND FÜR ÜBER **400** HERSTELLER



**MIT UNSEREN
MEISSELN IST ES
WIE BEI EINEM
STÜCK FLEISCH,
DIE QUALITÄT
MACHT DEN
UNTERSCHIED.**



Und jeder hat seine besonderen Wünsche.

Genau wie bei uns. Als OEM- bzw. Private-Label Lieferant mit höchstem Qualitätsniveau werden wir von unseren Kunden seit Jahrzehnten geschätzt. Viele namhafte Unternehmen vertrauen weltweit auf die Qualität von SOLIDA als Lieferant ihrer Einsteckwerkzeuge.

Hochflexibel in der Fertigung.

Als Hersteller sind wir in der Lage, den gesamten Fertigungsprozess auf die Anforderungen unserer Kunden anzupassen. Dazu gehören Sonderausführungen von Arbeitsseiten und Einsteckenden, Oberflächenbearbeitung, Laserlabeling auf dem Produkt und kundenspezifische Verpackung.

Ganz besondere Anforderungen.

Sonderlösungen für Spezialbranchen – auch das ist ein Gebiet, auf dem SOLIDA außergewöhnliche Werkzeuge herstellt, zum Beispiel für den Motorenbau oder zur Schlackeentfernung in unzugänglichen Bereichen von Gussteilen.

**WIR FERTIGEN NACH
IHREN WÜNSCHEN!**

Sprechen Sie uns an und
nennen Sie uns Ihre
Anforderungen und Mengen.

Wir beraten Sie gerne.
Rufen Sie uns an unter

T +49 2191 3715-0
oder mailen Sie an
sales@solida-werk.com

DAS GROSSE GANZE!

Service wird bei SOLIDA groß geschrieben, denn erst, wenn wir unsere Kunden über die Produkte hinaus zufriedenstellen können, sind wir es auch.



Lernen Sie unser Lager schätzen.

In unserem umfangreichen Lager halten wir für unsere Kunden viele gängige Einsteckwerkzeuge bereit, die meist am Tag der Bestellung noch in den Versand gehen. So sind wir in der Lage, Ihre Lieferwünsche schnellstmöglich zu erfüllen.



Ersatzteile sparen Geld.

Für mehrteilige Einsteckwerkzeuge halten wir die passenden Ersatzteile wie Platten, Adapter oder ganze Ersatzteilsets vor. Das schont Ressourcen und spart Ihnen bares Geld.



Wir arbeiten auf.

Selbstverständlich arbeiten wir entsprechend hochwertige Werkzeuge auch auf. Nach dem Eingang Ihrer benutzten Einsteckwerkzeuge prüfen wir, ob sich die Aufarbeitung wirtschaftlich lohnt und informieren Sie entsprechend. Bitte kontaktieren Sie uns vorab zu Details des Ablaufes und den Möglichkeiten unter **T +49 2191 3715-0**, oder mailen Sie an **sales@solida-werk.com**.



Lassen Sie sich beraten.

Wir unterstützen Sie mit all unserem Wissen, wenn Sie das richtige Produkt für einen Einsatzzweck suchen, Ihr benötigtes Einsteckende nicht auf Anhieb finden oder unsicher sind, ob Sie den richtigen Hammertyp zugeordnet haben. Unser Team ist geschult darin, schnell die richtigen Produkte für Ihre Wünsche auszuwählen. Wir freuen uns darauf, Sie beraten zu dürfen unter **T +49 2191 3715-0**, oder mailen Sie an **sales@solida-werk.com**.

hydraulic tools



**WIR FERTIGEN NACH
IHREN WÜNSCHEN!**
Sprechen Sie uns auf weitere
Sorten, Typen, Längen und
Ausführungen einfach an!
T +49 2191 3715-0

LEGENDE



= Arbeitsseite



= Einsteckende



= Breite



= Gesamtlänge



= Gewicht

—solida - Nr.

= Bestellnummer



= Baujahr/Version
beachten

solida®
GERMANY

ENDLOSE WEITE – ENDLOSE ZÄUNE

Die Kraft der Hydraulik wird für die unterschiedlichsten Einsätze genutzt. Immer häufiger geht es dabei nicht um Abbruch und Steinbrucharbeiten.

Beispielhafte Einsteckwerkzeuge

Breitmeißel

Universell im Einsatz, mit extra großer Breite und zusätzlicher Schneidwirkung. Zum Aufbruch von Asphaltdecken, Ausschlagen von Gießpfannen und zum Abbruch von Beton und Stahlbeton. Schneide steht quer zum Baggerausleger. Auch in 90° versetzt lieferbar!

Elefantenfuss

Zum Zertrümmern von armierten Betonflächen, Zerkleinern von Knäppern in Steinbrüchen. Einsatz auch zur Bodenverdichtung. Fertigung nach Maß. Arbeitsseiten- \varnothing max. 250 mm.

Sprengmeißel

Für alle Abbrucharbeiten in Beton und sehr zähem Gestein. Für Spezialabbrüche mit hoher Spaltwirkung. Pyramidal geschmiedete, abgerundete Spitze. Einsteckenden von \varnothing 55 bis 180 mm.

Rammglocke

Zum Einschlagen von Rohren und Pfählen in den Boden. Fertigung nach Maß. Außen- \varnothing max. 250 mm, Innen- \varnothing max. 200 mm.

10 Hektar Weide, ein Hydraulikhammer mit Rammglocke, und die Zeit läuft von Sonnenauf- bis Sonnenuntergang. Nicht immer ist es die Weite der Prärie, die umfriedet, oder eine Herde von Longhorns, deren Weide umgrenzt werden soll, wenn Pfähle in den Boden getrieben werden müssen. Baumschulen setzen Pfähle, um die Setzlinge zu stützen und zu schulen, im Weinbau werden die Reben an Drahtseilen zwischen Pfählen zum Spalier erzogen. Pfähle werden im gesamten Obst- bis zum Hopfenanbau benutzt, um den Pflanzen Halt zu geben. Landwirte und Viehzüchter setzen sie ein. Pfähle begrenzen Grundstücke und Gewässer, sie werden zu Zäunen und Stegen.

Mit den unterschiedlichsten Hammertypen und der SOLIDA-Rammglocke, die den Pfahl während des Einschlagens sauber führt, wird die Arbeit bestmöglich automatisiert und die Rammleistung optimiert.

So klappt es schließlich doch, dass das Lagerfeuer der Cowboys von heute prasselt, während der Sonnenuntergang den Tag beschließt.



Rammglocke

**WIR FERTIGEN NACH
IHREN WÜNSCHEN!**
Sprechen Sie uns auf weitere
Sorten, Typen, Längen und
Ausführungen einfach an!
T +49 2191 3715-0

Seite	Fabrikat	Serie	Typ
25 – 26	Arrowhead	S	10, 20, 30, 40, 50, 60
auf Anfrage	All-Kor	AKB	15, 40, 55, 70, 130, 160, 180
auf Anfrage	Arden	AB	100, 140, 150, 152, 200, 210, 212, 280, 282, 292, 350, 352, 450, 502, 550, 850, 852, 1050, 1052, 1100, 1450, 1850, 1852, 3100, 2450, 2452
27 – 31	Atlas Copco	SB	50, 52, 55, 102, 100 MK2, 100, 110, 150, 150 MK2, 152, 200, 202, 300, 302, 450, 452, 552, 702
		SBC	60, 115, 255, 410, 610, 650, 800, 850
		TEX	30 H, 75 H, 80 H, 100 H, 110 H, 180 H, 250 H, 400 H, 600 – 900 H, 1400 H, 1800 H, 2000 H
		SBU	160, 220, 340
		MB	500, 700, 750, 800, 1000, 1200, 1500, 1600, 1700
		HB	2000, 2200, 2500, 3000, 3100, 4100, 4200
		HBC	1100, 1700 HD, 2500, 4000
		PB	110, 160, 210, 310, 420, 530
auf Anfrage	Berco	BB	20, 70, 120, 170, 220
32 – 36	Bobcat	BB	42, 52, 62, 70, 80
		HB	280, 380, 580, 680, 880, 980, 1180, 1380, 2380
		B	290, 300, 400, 500, 600, 700, 850, 950, 1200, 1400 1250, 1560, 1750, 2500, 3500, 5060, 5500, 5560, 6560
37 – 39	Case	CB	140, 200, 370, 620, 735, 1150, 1450, 3750, 4000, 5200, 6000
37 – 39	CNH (Case New Holland)	CB	18, 27, 32, 37, 45, 65, 85, 90, 120, 150, 200 S, 260 S, 320 S, 400 S, 550 S, 700 S
40 – 43	Caterpillar	H	25 Ds, 35 Ds, 35 Es, 45, 45 s, 45 Ds, 50, 50 s, 55 Ds, 63, 63 s, 65 Ds, 70, 70 s, 90 C, 90Cs, 90, 100, 100 s, 115 s, 115 C, 120 Cs, 130, 130 C, 130 s, 140, 140 s, 140 Cs, 140 Ds, 160 Cs, 160 Ds, 180, 180 C, 180 s, 180 Ds
44 – 47	Chicago Pneumatic	CP	100, 100 H, 75 H, 80 H, 110 H, 150, 200, 180 H, 300, 250 H1, 290 H, 400, 550, 400 H, 750, 600 H, 700 H, 900 H, 1150, 1400 H, 1550, 1650, 1800 H, 2000 H, 2250, 3050, 4250
		RX	2, 3, 4, 6, 8, 11, 18, 25, 26, 29, 30, 38, 45, 46, 53, 54
auf Anfrage	Daemo	DMB	50, 140, 180, 210
auf Anfrage	Dehaco	S	150 V, 500 V, 1300 V, 1800 V, 2200 II, 4400 II
		DBH	07 S, 10 S, 15 S, 18, 65, 91
		DHB	35, 55, 75, 90 S, 100, 105, 150, 165, 200 S, 205, 250, 300 S, 305, 350, 400 S, 405, 501, 601, 805, 1000 S, 1105, 1250, 1305, 1405, 1500 S, 1605, 2000 S, 2200 S, 2305, 3205, 3600 S, 3601 S, 4200 S
auf Anfrage	Doosan	DXB	100, 130, 170
48 – 51	Drago	JSB	18 GS, 20 GS, 20 S, 30 GS, 30 S, 40 GS, 40 S, 50 S, 60 S, 81 S, 130 S, 151 S
		DRH	80, 120, 150, 180, 250, 280, 650, 900, 1150, 1600
		DBL	45, 53
		DBS	40, 45, 53, 68, 75
		DB	10 S, 15 S, 20 S, 25 S, 30 S, 35 S, 40 S, 100 S
auf Anfrage	DSM Daesan	KHB	1, 3, 4, 5, 6, 15, 20
52 – 53	D & A		7 V, 8 V, 15 V, 20 V, 30 V, 40 V, 50 V, 70 V, 80 V, 100 V, 130 V, 200 V, 220 V
		S	150, 200, 300, 500, 700, 800, 1000, 1300, 2200
54 – 56	Euroram	RM	45, 48, 56, 65, 70, 75, 80, 82, 85, 90, 110, 115, 120, 130, 140, 145, 150, 160
57 – 58	Everdigm	EHB	008, 01, 02, 03, 04, 05, 06, 10, 13, 17
59 – 63	Furukawa	F	1, 2, 3, 4, 5, 6, 9, 12, 19, 20, 22, 27, 30, 35, 45, 70
		FX	15, 25, 35, 45, 55, 65, J 175, J 275
		HB	1 G, 2 G, 2,5 G, 3 R, 100, 3 G, 200, 5 G, 8 G, 10 G, 15 G, 20 G, 30 G, 40 G
54 – 56	Globram	RM	45, 48, 56, 65, 70, 75, 80, 82, 85, 90, 110, 115, 120, 130, 140, 145, 150, 160
64 – 65	Hanwoo	RHB	302 V, 302, 303 V, 304, 305 V, 306, 308 V, 309, 313 V, 320, 322 V, 323, 325
66 – 67	Huppenkothen	Huppi	52, 72, 102, 302, 402, 902
auf Anfrage	Hutter	H	50, 61, 85, 100, 140, 180, 320, 400
auf Anfrage	Inan Makina	GA	150, 200, 300, 400
68 – 70	Indeco	MTB	15, 20, 25, 30, 35, 36, 40, 45, 120, 150, 170, 210, 215, 255, 270, 275, 360
		HP	150, 200, 350, 500, 600, 700, 900, 1200
		HB	5, 8, 12, 19, 27
		MES	121, 150, 180, 181, 200, 250, 300, 301, 350, 351, 450, 451, 521, 550, 553, 601, 621, 650, 1050, 1200, 1500, 1800, 1750, 2000, 2500, 3000, 3500, 4000, 5000
		UP	181, 200, 301, 350, 351, 462, 521, 550, 553, 601, 621, 650, 1200
auf Anfrage	Italdem	GK	85, 86, 160, 161, 211, 290, 291, 360, 361, 600, 610, 620, 950, 1050, 1800
71 – 72	JAB	IM	30, 30 S, 50 S, 65, 70, 100
		K	80, 270, 550, 1000, 1030, 1300, 1900
		MK	95, 135, 350, 270, 650
73 – 75	JCB Hammermaster	JB	8, 10, 20, 30, 40, 60, 70, 71, 80
auf Anfrage	Jisung	HM	65, 80, 100, 100Q, 115, 160, 160 Q, 165 Q, 166 Q, 260, 260 Q, 265 Q, 266 Q, 360, 360 Q, 385 Q, 386 Q, 495 Q, 496 Q, 860 Q, 1260 Q, 1560 Q, 1570 Q, 1760 Q, 2460 Q, 3060 Q, 4160 Q
59 – 63	Kent	JSB	10, 20, 20G, 30, 30G, 40, 40G, 43, 50, 60, 81, 100, 121, 130, 151
		KF	1, 2, 3, 4, 5, 6, 9, 12, 19, 22, 27, 35, 45, 70,
		KHB	1 G, 20, 2 GII, 30, 3 GII, 50, 5 GII, 80, 8 GII, 100, 10 GII-HD, 150, 15 GII, 200, 20 GII, 300, 30 GII, 400, 40 GII
76 – 78	Komac	KB	90, 100, 150, 200, 250, 300, 350, 400, 1000, 1500, 2000, 3600, 4200
		TOR	22, 23, 36

Diese Liste enthält unser Standardprogramm. Weitere Sorten, Typen, Längen und Ausführungen sind auf Wunsch lieferbar.
Änderungen vorbehalten! Mit dem Erscheinen dieser Liste verlieren alle früheren Listen ihre Gültigkeit.

Seite	Fabrikat	Serie	Typ
79 – 82	Komatsu	JTHB	08, 10, 20, 40, 50, 60, 65, 70, 100, 190, 230
		JKHB	51, 71, 101, 301, 401, 801, 1101, 1401, 1500, 2000
80	Komatsu utility	PC	09-1, 03-2 (FAI)
83 – 86	Krupp	HM	45, 55, 50, 51, 53, 60, 60 V, 61, 62, 65, 75, 85, 90 V, 100, 110, 130, 131, 135, 140 V, 170, 185, 190 V, 200, 220, 230, 300, 301, 303, 305, 400, 401, 405, 350 V, 550, 551, 553, 555, 560, 560 CS, 560 V, 580, 600, 601, 680, 700, 701, 702, 703, 705, 706, 720 CS, 710, 711, 712, 713, 715, 720, 720 V, 780, Marathon, 800, 900, 901, 902, 904, 950, 951, 952, 954, 957, 960 CS, 960 V, 1000, 1300, 1500, 1500 CS, 1500 V, 1800, 2000, 2100, 2300, 2200, 2500, 2600
		KM	55, 100, 105, 150, 155, 200, 205, 300, 305, 450, 455
87 – 89	Kubota	KXB	300 N, 350 N, 400 N, 450 N, 500 N, 600 N
90	Lifton	LH	60, 70, 80, 100, 110, 200, 300, 170, 360
auf Anfrage	LST	GS	125, 250, 501
		XB	075, 110, 175, 250, 340, 400, 450, 675, 875, 1100, 1300, 1700, 2100, 2300, 2700, 3100, 4100
auf Anfrage	Maruzen	MBB	50, 60, 70
91 – 96	Montabert	BRP	30, 45, 50, 70, 60, 85, 95, 100, 130, 140, 150
		BRH	40, 45, 75, 76, 90, 91, 125, 250, 270, 501, 570, 620, 625, 750, 900
		BRV	32
		M	30, 50, 60, 70, 85, 95, 125 SX, 130, 140, 150, 300, 700, 900
		SC	6, 8, 12, 16, 22, 28, 36, 42, 50
		V	32, 1200, 1800, 2500
97 – 99	MSB	Saga	20, 20 H, 20 II, 30, 30 H, 30 II, 40, 40 H, 40 II, 50, 50 H, 2000, 80, 80 H, 100, 100 H, 120, 120 H, 180, 180 H
		MS	200, 200 H, 220, 220 H, 225, 225 H, 250, 250 H, 255, 255 H, 300, 300 H, 400, 400 H, 450 H, 460, 460 H, 500, 500 H, 520, 520 H, 550, 550 H, 600, 600 H
		NE	6, 8, 12, 16, 22, 28, 36, 42, 50, 300
102 – 107	NPK	E	102, 106, 200, 201, 202, 203, 204, 205, 206, 207, 208, 12-X, 212, 210-A, 213, 213-A, 15-X, 215, 18-X, 216, 218, 224, 24-X, 220, 225
		GH	06, 07, 1, 2, 3, 4, 6, 9, 10, 15, 18
		H	06-X, 08-X, 1-XA, 2-XA, XE, 3-XA/XE, 2-X, 4-X/XE, 5-X, 6-X, 7-X, 8-X, 8-XA, 10-X, 10-XB, 10-XE, 12-X, 12-XE, 16-XD, 16-XE
auf Anfrage	O & K	H	32, 45, 65, 85, 120, 150, 200, 260, 310, 380, 530, 700
auf Anfrage	Okada	TOP	35, 60 B
		OKB	301, 302 A, 303 B, 305, 306, 312, 312 B, 316
auf Anfrage	Omali	HB	66, 80, 80 S, 86, 90, 120, 150, 270, 275, 400, 500, 501, 550, 1000, 1050, 1056, 1060
auf Anfrage	Promove	MHD	9, 15, 25, 29, 170 PS
		P	3, 3 P, 3 SH, 5, 5 P, 6, 6 P, 6 SB, 6 SH, 12, 12 SB, 12 SH, 16, 16 SH, 18 PS, 22, 23, 24, 27, 32, 35
		PMV	90, 110, 150, 190, 230, 290, 390, 690, 1000, 1390, 1590
		XP	70, 100, 150, 250, 450, 800, 4500
108 – 113	Rammer		111, 155, 222, 255, 355, 333, 455, 555, 777, 999, 1533
		S	Piccolo, 18, 21, 22, 20, 23, 23 N, 25, 27, 26, 26 N, 29, 52, 54, 55, 56, 83
		E	64, 63, 66, 66 N, 65, 68, 69
		M	14, 18
		G	80, 88, 90, 100, 110
auf Anfrage	Robi	BH	30, 32, 40, 50, 52, 80
		EH	100, 140, 170, 240
		MH	7, 11, 15
114-115	Rotair	OL	90, 130, 180, 250
		OLS	50, 95, 160, 260, 330, 450, 550
108 – 113	Sandvik	BR	111, 155, 255, 222, 321, 355, 422, 333, 455, 623, 825, 555, 777, 927, 999, 1229, 1533, 2064, 2063, 2266, 2265, 2214, 2568, 2577, 2518, 3088, 3288, 3890, 4510, 4511
auf Anfrage	Schaeff	SH	50, 70, 85, 95, 140
116 – 117	Socomec	DMS	50, 95, 150, 160, 165, 210, 220, 260, 270, 310, 330, 680, 740, 850
118 – 119	Soosan	SB	10, 20, 20 II, 30, 30 II, 35, 35 II, 40, 40 II, 4, 43, 43 II, 45, 50, 60, 81, 121
auf Anfrage	Stanley	MB	05, 15 EX, 20 EX, 30 EX, 40 EX, 50 EX, 70 EX, 100 EX, 105, 125, 156, 250, 256, 257, 350, 356, 357, 506, 550, 556, 557, 656, 675, 695, 800, 856, 875, 956, 5950, X15, X308, X608
auf Anfrage	Star	SH	40, 90, 91, 151, 200, 260, 280, 281, 330, 370, 450, 560, 561, 562, 700, 990, 991, 992, 1200, 1400, 1950, 2000
122 – 123	Takeuchi	TKB	51, 50, 71, 101, 301, 401, 801, 1101, 1401, 1400, 1600, 2000
auf Anfrage	Tecna	HF	15, 16, 30, 32, 40, 41, 44, 45, 50, 51, 55, 56, 190, 200, 260, 270, 320
120 – 121	Toku	TNB	08 M, 1 M, 1 E, 2 M, 2 E, 3 M, 3 E, 4 E, 5 M, 5 E, 6 E, 6,5 E, 7 E, 8 E, 10 E, 100, 14 E, 16 E, 150/151, 190, 220/230
122 – 123	Toyo	THBB	51, 50, 71, 101, 301, 401, 801, 1101, 1401, 1400, 1600, 2000
auf Anfrage	Vibra-Ram	VRH	50, 60, 75, 90, 100, 115, 135, 145, 155
		HBS	6, 12, 20, 25, 31
124	Vistarini	VH	60, 90, 120, 160, 220, 240, 250
		VHX	90, 120, 200, 250, 300, 330, 331
		HB	80, 95, 130, 150, 160, 200, 260, 300, 330, 440, 450, 600, 800, 1100, 1400, 1700, 2400, 3200, 3800
auf Anfrage	Volvo	MH	90, 95, 130, 160, 180, 260, 330
		W	115, 220, 275, 330, 440, 550, 600, 660
125 – 126	Wimmer	WH	4, 5, 6, 8, 17, 22, 26

Diese Liste enthält unser Standardprogramm. Weitere Sorten, Typen, Längen und Ausführungen sind auf Wunsch lieferbar. Änderungen vorbehalten! Mit dem Erscheinen dieser Liste verlieren alle früheren Listen ihre Gültigkeit.

**Stampfmeissel**

Der vielseitige Stampfmeissel. Ideal zum Brechen von Gesteinsblöcken, zum Zerkleinern von Knäppern im Steinbruch und zum Zerkleinern von Schlacke. Auch geeignet zur Bodenverdichtung.

**Spitzmeissel**

Der Universalmeissel für Abbrucharbeiten und im Steinbruch. Ideal zum Zerkleinern von Schlacke in Stahlwerken/Industrie, zum Abbruch von Fundamenten. Im Bergbau für den Streckenvortrieb und Streckenabschlag. Spitze pyramidal geschmiedet für die Keilwirkung beim Einsatz.

**Flachmeissel**

Universell im Einsatz, mit zusätzlicher Schneidwirkung. Optimal auch zum Ziehen von Gräben in felsigem Untergrund und Trennen von großen Gesteinsplatten. Schneide steht quer zum Baggerausleger. Auch in 90° versetzt lieferbar!

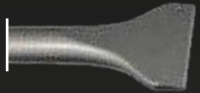
**Breitmeissel**

Universell im Einsatz, mit extra großer Breite und zusätzlicher Schneidwirkung. Zum Aufbruch von Asphaltdecken, Ausschlagen von Gießpfannen und zum Abbruch von Beton und Stahlbeton. Schneide steht quer zum Baggerausleger. Auch in 90° versetzt lieferbar!

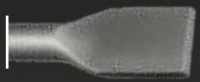
**Asphaltspaten**

Universell im Einsatz, mit extra langem Blatt und zusätzlicher Schneidwirkung. Zum Schneiden von Asphalt oder weichem Material. Schneide steht parallel zum Baggerausleger. Auch in 90° versetzt lieferbar!

**Rohreintreiber**

Zum Einschlagen von Rohren in den Boden. Fertigung nach Maß.

**Rammglocke**

Zum Einschlagen von Rohren und Pfählen in den Boden. Fertigung nach Maß. Außen- \varnothing max. 250 mm, Innen- \varnothing max. 200 mm.

**Elefantenfuss**

Zum Zertrümmern von armierten Betonflächen, Zerkleinern von Knäppern in Steinbrüchen. Einsatz auch zur Bodenverdichtung. Fertigung nach Maß. Arbeitsseiten- \varnothing max. 250 mm.

**Stampfwerkzeug**

Zur Verdichtung von Erdreich und Kiesbelag. Mit geschmiedeter Platte 200 x 200 mm. Inkl. Adapter für Einsteckenden bis \varnothing max. 75 mm.

**Sprengmeissel**

Für alle Abbrucharbeiten in Beton und sehr zähem Gestein. Für Spezialabbrüche mit hoher Spaltwirkung. Pyramidal geschmiedete, abgerundete Spitze. Für Einsteckenden von \varnothing 55 bis 180 mm.





**Spitzmeissel mit Staubnuten**

Die Alternative für staubintensive Arbeiten. Für universellen Einsatz bei Abbrucharbeiten, im Steinbruch und den Abbruch von Fundamenten. Pyramidal geschmiedete Spitze mit 4 Staubnuten. Für Einsteckenden ab \varnothing 70 mm.

**Spitzmeissel mit langen Staubnuten**

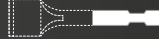
Die Alternative für besonders staubintensive Arbeiten. Für universellen Einsatz bei Abbrucharbeiten, im Steinbruch und den Abbruch von Fundamenten. Pyramidal geschmiedete Spitze mit 4 langen Staubnuten. Für Einsteckenden von \varnothing 110 bis 130 mm.

Alle Einsteckwerkzeuge von SOLIDA sind nur für ihren bestimmungsgemäßen Gebrauch in den mit den passenden Werkzeugaufnahmen versehenen Maschinen bestimmt und geeignet. Darüber hinaus sind die Bedienungsanleitungen und Sicherheitshinweise der Maschinenhersteller zu beachten. Für diesbezüglichen Fehlgebrauch übernimmt SOLIDA keine Haftung.

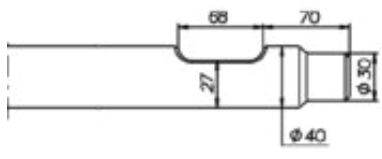
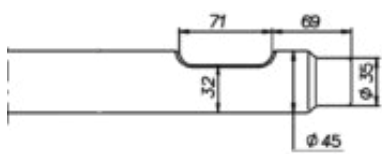
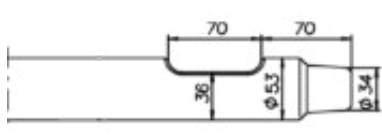
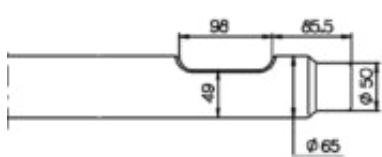
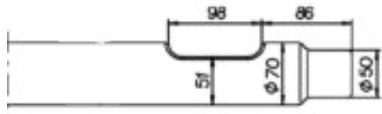
						solida - Nr.
Arrowhead S10						
Spitzmeissel		-	460	4		70 918 01 046
Flachmeissel (quer)		42	460	4		70 918 02 046
Breitmeissel (quer)		120	410	4		70 918 70 041
Asphaltspaten (parallel)		100	440	4		70 918 43 044
Stempfwerkzeug		200 x 200	420	16		70 918 95 042
Arrowhead S20						
Spitzmeissel		-	500	5,5		70 904 01 050
Flachmeissel (quer)		45	500	5,5		70 904 02 050
Breitmeissel (quer)		120	460	5,5		70 904 70 046
Asphaltspaten (parallel)		100	470	5,5		70 904 43 047
Stempfwerkzeug		200 x 200	470	17		70 904 95 047
Arrowhead S30						
Spitzmeissel		-	580	9		70 903 01 058
Flachmeissel (quer)		55	580	9		70 903 02 058
Breitmeissel (quer)		140	550	9		70 903 18 055
Asphaltspaten (parallel)		120	560	9		70 903 83 056
Stempfwerkzeug		200 x 200	550	21		70 903 95 055
Arrowhead S40						
Spitzmeissel		-	600	13,5		70 919 01 060
Flachmeissel (quer)		65	600	13,5		70 919 02 060
Breitmeissel (quer)		150	550	13,5		70 919 34 055
Asphaltspaten (parallel)		130	570	13,5		70 919 69 057
Stempfwerkzeug		200 x 200	550	25		70 919 95 055
Arrowhead S50						
Spitzmeissel		-	740	19		70 905 01 074
Flachmeissel (quer)		70	740	19		70 905 02 074
Breitmeissel (quer)		150	690	19		70 905 34 069
Asphaltspaten (parallel)		150	720	19		70 905 65 072
Stempfwerkzeug		200 x 200	550	31		70 905 95 069



Arrowhead S60

Spitzmeissel		-	720	21	70 906 01 072
Flachmeissel (quer)		75	720	21	70 906 02 072
Breitmeissel (quer)		150	670	21	70 906 34 067
Asphaltspaten (parallel)		150	700	21	70 906 65 070
Stampfwerkzeug		200 x 200	670	33	70 906 95 067



Atlas Copco SB 200 / 202 / SBC 410 / SBU 220 / TEX 180 H

Spitzmeissel		-	600	13	70 509 01 060
Spitzmeissel		-	800	19	70 509 01 080
Flachmeissel (quer)		65	600	13	70 509 02 060
Breitmeissel (quer)		125	650	16	70 509 16 065
Asphaltspaten (parallel)		130	670	16	70 509 69 067
Stampfwerkzeug		200 x 200	550	24	70 509 95 055

Atlas Copco SB 300 / 302 / SBC 610 / 650 / SBU 340

Spitzmeissel		-	800	28	70 514 01 080
Flachmeissel (quer)		80	800	28	70 514 02 080
Breitmeissel (quer)		160	770	28	70 514 20 077
Asphaltspaten (parallel)		180	790	28	70 514 53 079

Atlas Copco SB 450 / 452 / SBC 800 / 850 / TEX 400 H

Spitzmeissel		-	840	41	70 511 01 084
Flachmeissel (quer)		95	840	41	70 511 02 084
Breitmeissel (quer)		180	800	41	70 511 22 080
Asphaltspaten (parallel)		200	830	41	70 511 55 083

Atlas Copco SB 552

Spitzmeissel		-	900	49	70 523 01 090
Flachmeissel (quer)		100	900	49	70 523 02 090
Breitmeissel (quer)		200	850	49	70 523 24 085

Atlas Copco SB 702







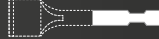

Spitzmeissel		-	1050	64	70 035 01 105
Flachmeissel (quer)		105	1050	64	70 035 02 105
Breitmeissel (quer)		200	1000	64	70 035 24 100
Stampfmeissel		-	980	64	70 035 00 098

Atlas Copco MB 500

Spitzmeissel		-	900	39	70 024 01 090
Flachmeissel (quer)		90	900	39	70 024 02 090
Breitmeissel (quer)		180	840	39	70 024 22 084
Asphaltspaten (parallel)		200	880	39	70 024 55 088

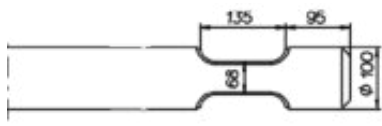
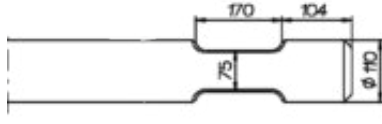
Atlas Copco MB 700 / MB 800

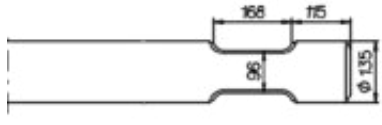
Spitzmeissel		-	1000	56	70 027 01 100
Flachmeissel (quer)		100	1000	56	70 027 02 100
Breitmeissel (quer)		200	950	56	70 027 24 095
Stampfmeissel		-	930	56	70 027 00 093

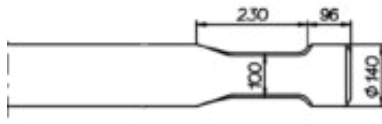
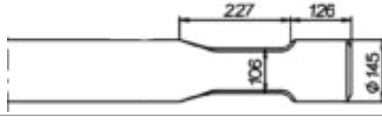
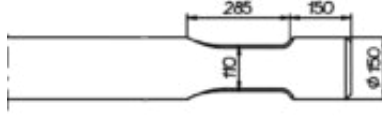
						_solida - Nr.
Atlas Copco MB 750						
Spitzmeissel		-	1000	54	70 524 01 100	
Flachmeissel (quer)		100	1000	54	70 524 02 100	
Breitmeissel (quer)		200	950	54	70 524 24 095	
Stampfmeissel		-	930	54	70 524 00 093	
Atlas Copco MB 1000						
Spitzmeissel		-	1100	79	70 034 01 110	
Flachmeissel (quer)		110	1100	79	70 034 02 110	
Breitmeissel (quer)		240	1040	79	70 034 26 104	
Stampfmeissel		-	1020	79	70 034 00 102	
Atlas Copco MB 1200						
Spitzmeissel		-	1100	87	70 028 01 110	
Flachmeissel (quer)		120	1100	87	70 028 02 110	
Stampfmeissel		-	1020	87	70 028 00 102	
Atlas Copco MB 1500						
Spitzmeissel		-	1200	118	70 525 01 120	
Flachmeissel (quer)		135	1200	118	70 525 02 120	
Stampfmeissel		-	1100	118	70 525 00 110	
Atlas Copco MB 1600						
Spitzmeissel		-	1100	107	70 018 01 110	
Sprengmeissel		-	1200	107	70 018 90 120	
Flachmeissel (quer)		135	1100	107	70 018 02 110	
Stampfmeissel		-	1000	107	70 018 00 100	
Atlas Copco MB 1700						
Spitzmeissel		-	1200	128	70 026 01 120	
Flachmeissel (quer)		140	1200	128	70 026 02 120	
Stampfmeissel		-	1100	128	70 026 00 110	
Atlas Copco HB 2000						
Spitzmeissel		-	1230	141	70 527 01 123	
Flachmeissel (quer)		145	1230	141	70 527 02 123	
Atlas Copco HB 2200						
Spitzmeissel		-	1300	160	70 030 01 130	
Flachmeissel (quer)		150	1300	160	70 030 02 130	
Stampfmeissel		-	1200	160	70 030 00 120	



Atlas Copco HB 2500

Spitzmeißel		-	1300	175	70 528 01 130
Flachmeißel (quer)		155	1300	175	70 528 02 130
Stampfmeißel		-	1200	175	70 528 00 120

Atlas Copco HB 3000 / HB 3100

Spitzmeißel		-	1350	197	70 032 01 135
Flachmeißel (quer)		165	1350	197	70 032 02 135
Stampfmeißel		-	1250	197	70 032 00 125

Atlas Copco HB 4100 / HB 4200

Spitzmeißel		-	1700	308	70 033 01 170
Flachmeißel (quer)		180	1700	308	70 033 02 170
Stampfmeißel		-	1600	308	70 033 00 160

Atlas Copco TEX 250 H

Spitzmeißel		-	800	27	70 505 01 080
Flachmeißel (quer)		80	800	27	70 505 02 080
Breitmeißel (quer)		160	770	27	70 505 20 077
Asphaltspaten (parallel)		180	790	27	70 505 53 079

Atlas Copco HBC 1100 / 1700 HD / TEX 600-900 H









Spitzmeißel		-	900	54	70 506 01 090
Flachmeißel (quer)		105	900	54	70 506 02 090

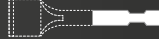



Atlas Copco HBC 2500 / TEX 1400 H

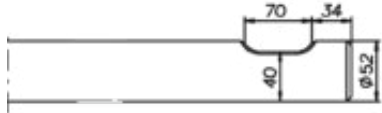
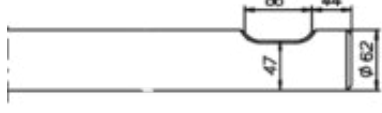



Spitzmeißel		-	1100	95	70 508 01 110
Flachmeißel (quer)		125	1100	95	70 508 02 110
Stampfmeißel		-	1020	95	70 508 00 102



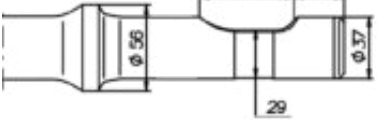
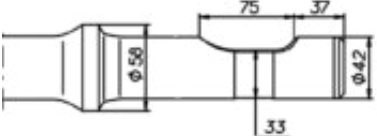
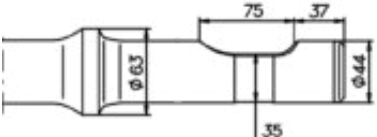
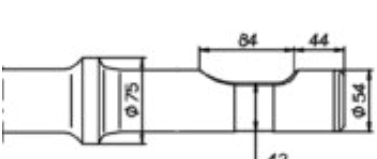
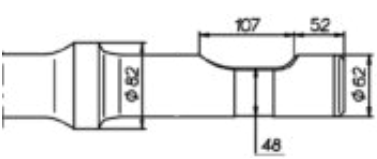

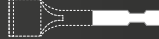
Atlas Copco HBC 4000 / TEX 1800 / 2000 H



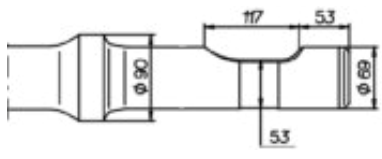
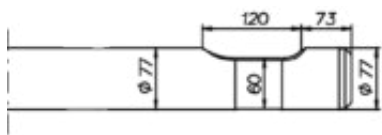
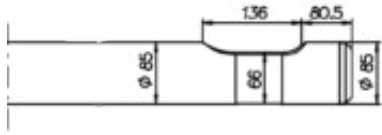
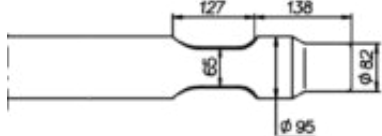
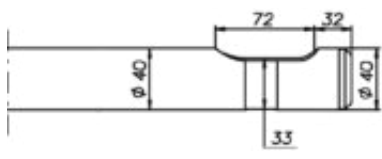

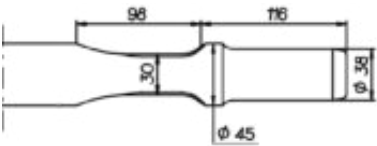
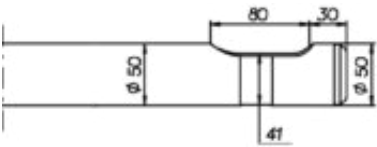
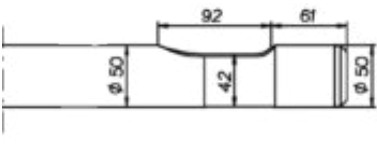
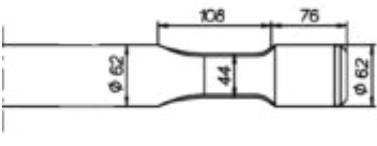
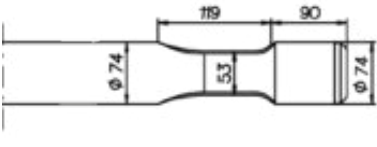

Spitzmeißel		-	1100	108	70 507 01 110
Flachmeißel (quer)		135	1100	108	70 507 02 110
Stampfmeißel		-	1000	108	70 507 00 100

						
Atlas Copco PB 110 / AT 20						
Spitzmeißel		-	410	4		70 110 01 041
Spitzmeißel		-	500	5		70 110 01 050
Flachmeißel (quer)		42	410	4		70 110 02 041
Breitmeißel (quer)		120	370	4		70 110 70 037
Asphaltspaten (parallel)		100	380	4		70 110 43 038
Stampfwerkzeug		200 x 200	380	16		70 110 95 038
Atlas Copco PB 160 / AT 70						
Spitzmeißel		-	530	8		70 111 01 053
Spitzmeißel		-	680	11		70 111 01 068
Flachmeißel (quer)		52	530	8		70 111 02 053
Breitmeißel (quer)		140	500	8		70 111 18 050
Asphaltspaten (parallel)		115	510	8		70 111 83 051
Stampfwerkzeug		200 x 200	500	20		70 111 95 050
Atlas Copco PB 210 / AT 120						
Spitzmeißel		-	600	12		70 112 01 060
Spitzmeißel		-	750	17		70 112 01 075
Flachmeißel (quer)		62	600	12		70 112 02 060
Breitmeißel (quer)		150	550	12		70 112 34 055
Asphaltspaten (parallel)		130	570	12		70 112 69 057
Stampfwerkzeug		200 x 200	550	23		70 112 95 055
Atlas Copco PB 310 / AT 170						
Spitzmeißel		-	740	20		70 113 01 074
Flachmeißel (quer)		70	740	20		70 113 02 074
Breitmeißel (quer)		150	690	20		70 113 34 069
Asphaltspaten (parallel)		150	720	20		70 113 65 072
Stampfwerkzeug		200 x 200	690	31		70 113 95 069
Atlas Copco PB 420 / 530 / AT 220						
Spitzmeißel		-	800	29		70 029 01 080
Flachmeißel (quer)		80	800	29		70 029 02 080
Breitmeißel (quer)		160	760	29		70 029 20 076
Asphaltspaten (parallel)		150	790	29		70 029 65 079

						kg	solida - Nr.
Bobcat HB 280							
Spitzmeissel		–	440	4	70 082 01 044		
Flachmeissel (quer)		40	440	4	70 082 02 044		
Breitmeissel (quer)		120	410	5	70 082 70 041		
Asphaltspaten (parallel)		100	430	5	70 082 43 043		
Stampfwerkzeug		200 x 200	420	17	70 082 95 042		
Bobcat HB 380							
Spitzmeissel		–	440	5	70 080 01 044		
Flachmeissel (quer)		42	440	5	70 080 02 044		
Breitmeissel (quer)		120	390	5	70 080 70 039		
Asphaltspaten (parallel)		100	400	5	70 080 43 040		
Stampfwerkzeug		200 x 200	410	17	70 080 95 041		
Bobcat HB 580							
Spitzmeissel		–	460	6	70 076 01 046		
Flachmeissel (quer)		45	460	6	70 076 02 046		
Breitmeissel (quer)		140	430	6	70 076 18 043		
Asphaltspaten (parallel)		115	440	6	70 076 83 044		
Stampfwerkzeug		200 x 200	430	17	70 076 95 043		
Bobcat HB 680							
Spitzmeissel		–	540	9	70 079 01 054		
Spitzmeissel		–	700	13	70 079 01 070		
Flachmeissel (quer)		54	540	9	70 079 02 054		
Breitmeissel (quer)		140	500	9	70 079 18 050		
Asphaltspaten (parallel)		115	510	9	70 079 83 051		
Stampfwerkzeug		200 x 200	510	21	70 079 95 051		
Bobcat HB 880							
Spitzmeissel		–	600	14	70 077 01 060		
Flachmeissel (quer)		62	600	14	70 077 02 060		
Breitmeissel (quer)		150	540	14	70 077 34 054		
Asphaltspaten (parallel)		130	560	14	70 077 69 056		
Stampfwerkzeug		200 x 200	550	24	70 077 95 055		

						
Bobcat HB 980						
Spitzmeissel		-	650	19	70 078 01 065	
Flachmeissel (quer)		69	650	19	70 078 02 065	
Breitmeissel (quer)		180	610	19	70 078 22 061	
Asphaltspaten (parallel)		200	660	20	70 078 55 066	
Stempfwerkzeug		200 x 200	600	28	70 078 95 060	
Bobcat HB 1180						
Spitzmeissel		-	700	23	70 081 01 070	
Flachmeissel (quer)		77	700	23	70 081 02 070	
Breitmeissel (quer)		150	650	23	70 081 34 065	
Asphaltspaten (parallel)		160	680	23	70 081 63 068	
Bobcat HB 1380						
Spitzmeissel		-	790	31	70 083 01 079	
Flachmeissel (quer)		85	790	31	70 083 02 079	
Breitmeissel (quer)		180	740	31	70 083 22 074	
Asphaltspaten (parallel)		180	770	31	70 083 53 077	
Bobcat HB 2380						
Spitzmeissel		-	850	41	70 074 01 085	
Flachmeissel (quer)		95	850	41	70 074 02 085	
Breitmeissel (quer)		200	800	41	70 074 24 080	
Asphaltspaten (parallel)		200	830	41	70 074 55 083	
Bobcat B 290 / B 300						
Spitzmeissel		-	410	4	70 068 01 041	
Spitzmeissel		-	560	6	70 068 01 056	
Flachmeissel (quer)		42	410	4	70 068 02 041	
Breitmeissel (quer)		120	440	5	70 068 70 044	
Asphaltspaten (parallel)		100	450	5	70 068 43 045	
Stempfwerkzeug		200 x 200	380	15	70 068 95 038	

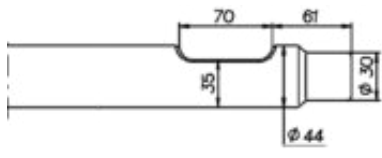
						kg	solida - Nr.
Bobcat B 400							
Spitzmeissel		-	500	6	70 055 01 050		
Spitzmeissel		-	700	8	70 055 01 070		
Flachmeissel (quer)		45	500	6	70 055 02 050		
Breitmeissel (quer)		120	460	6	70 055 70 046		
Asphaltspaten (parallel)		100	470	6	70 055 43 047		
Stampfwerkzeug		200 x 200	470	17	70 055 95 047		
Bobcat B 500							
Spitzmeissel		-	430	6	70 065 01 043		
Spitzmeissel		-	750	11	70 065 01 075		
Flachmeissel (quer)		50	430	6	70 065 02 043		
Breitmeissel (quer)		140	400	6	70 065 18 040		
Asphaltspaten (parallel)		115	410	6	70 065 83 041		
Stampfwerkzeug		200 x 200	400	17	70 065 95 040		
Bobcat B 600 / B 700							
Spitzmeissel		-	510	8	70 064 01 051		
Spitzmeissel		-	750	11	70 064 01 075		
Flachmeissel (quer)		50	510	8	70 064 02 051		
Breitmeissel (quer)		140	480	8	70 064 18 048		
Asphaltspaten (parallel)		115	490	8	70 064 83 049		
Stampfwerkzeug		200 x 200	480	18	70 064 95 048		
Bobcat B 850 / B 950							
Spitzmeissel		-	600	13	70 070 01 060		
Spitzmeissel		-	900	21	70 070 01 090		
Flachmeissel (quer)		62	600	13	70 070 02 060		
Breitmeissel (quer)		150	550	13	70 070 34 055		
Asphaltspaten (parallel)		130	570	13	70 070 69 057		
Stampfwerkzeug		200 x 200	550	23	70 070 95 055		
Bobcat B 1200 / B 1400							
Spitzmeissel		-	720	22	70 069 01 072		
Flachmeissel (quer)		75	720	22	70 069 02 072		
Breitmeissel (quer)		150	670	22	70 069 34 067		
Asphaltspaten (parallel)		150	700	22	70 069 65 070		
Stampfwerkzeug		200 x 200	670	31	70 069 95 067		

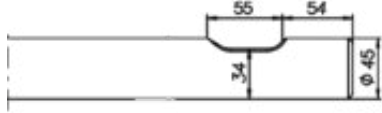
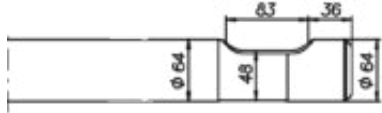
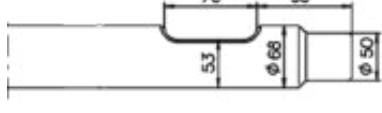
						kg	solida - Nr.
Bobcat 1250							
Spitzmeissel		-	480	5			70 850 01 048
Flachmeissel (quer)		45	480	5			70 850 02 048
Breitmeissel (quer)		120	440	5			70 850 70 044
Asphaltspaten (parallel)		100	450	5			70 850 43 045
Stampfwerkzeug		200 x 200	450	17			70 850 95 045
Bobcat 1560							
Spitzmeissel		-	480	5			70 856 01 048
Flachmeissel (quer)		45	480	5			70 856 02 048
Breitmeissel (quer)		120	440	5			70 856 70 044
Asphaltspaten (parallel)		100	450	5			70 856 43 045
Stampfwerkzeug		200 x 200	450	17			70 856 95 045
Bobcat 1750							
Spitzmeissel		-	480	6			70 566 01 048
Spitzmeissel		-	580	7			70 566 01 058
Flachmeissel (quer)		45	480	6			70 566 02 048
Breitmeissel (quer)		120	440	6			70 566 70 044
Asphaltspaten (parallel)		100	450	6			70 566 43 045
Stampfwerkzeug		200 x 200	450	17			70 566 95 045
Bobcat 2500 / 3500							
Spitzmeissel		-	600	13			70 851 01 060
Flachmeissel (quer)		65	600	13			70 851 02 060
Breitmeissel (quer)		150	550	13			70 851 34 055
Asphaltspaten (parallel)		130	570	13			70 851 69 057
Stampfwerkzeug		200 x 200	550	24			70 851 95 055
Bobcat 5060							
Spitzmeissel		-	740	19			70 857 01 074
Flachmeissel (quer)		70	740	19			70 857 02 074
Breitmeissel (quer)		150	690	19			70 857 34 069
Asphaltspaten (parallel)		150	720	19			70 857 65 072
Stampfwerkzeug		200 x 200	690	30			70 857 95 069

**Bobcat 5500**







Spitzmeissel		–	740	20	70 852 01 074
Flachmeissel (quer)		70	740	20	70 852 02 074
Breitmeissel (quer)		150	690	20	70 852 34 069
Asphaltspaten (parallel)		150	720	20	70 852 65 072
Stampfwerkzeug		200 x 200	690	32	70 852 95 069



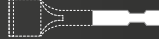



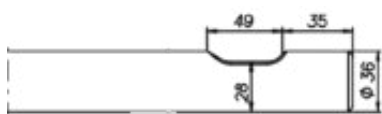

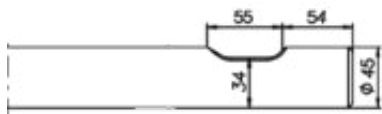
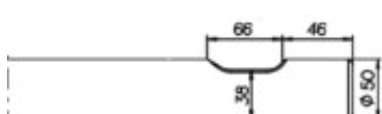
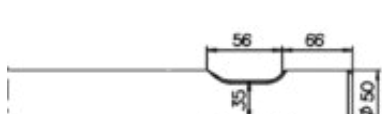
Bobcat 5560



Spitzmeissel		–	740	20	70 859 01 074
Flachmeissel (quer)		70	740	20	70 859 02 074
Breitmeissel (quer)		150	690	20	70 859 34 069
Asphaltspaten (parallel)		150	720	20	70 859 65 072
Stampfwerkzeug		200 x 200	690	32	70 859 95 069

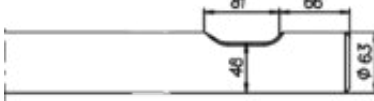
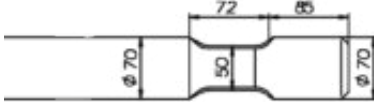

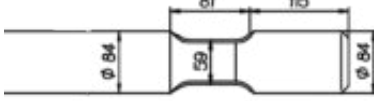

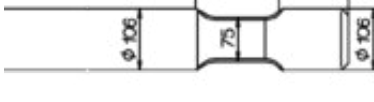

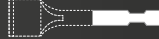

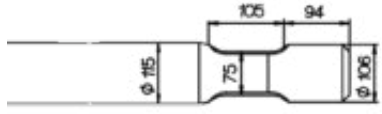
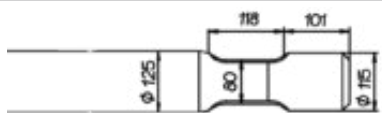
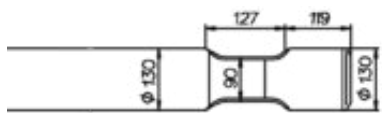
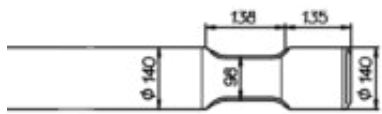
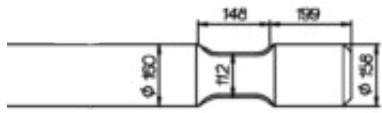
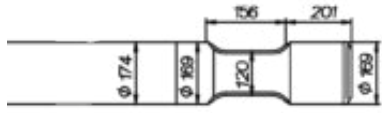

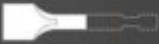
Bobcat 6560





Spitzmeissel		–	700	23	70 858 01 070
Flachmeissel (quer)		76	700	23	70 858 02 070
Breitmeissel (quer)		180	660	23	70 858 22 066

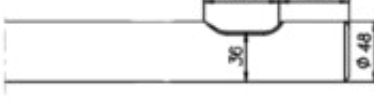



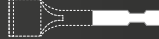

						solida - Nr.
CNH CB 18						
Spitzmeissel		-	360	4		70 587 01 036
Spitzmeissel		-	600	6		70 587 01 060
Flachmeissel (quer)		42	360	4		70 587 02 036
Breitmeissel (quer)		120	350	4		70 587 70 035
Asphaltspaten (parallel)		100	380	4		70 587 43 038
CNH CB 27						
Spitzmeissel		-	410	4		70 588 01 041
Spitzmeissel		-	600	6		70 588 01 060
Flachmeissel (quer)		42	410	4		70 588 02 041
Breitmeissel (quer)		120	390	5		70 588 70 039
Asphaltspaten (parallel)		100	420	5		70 588 43 042
Stampfwerkzeug		200 x 200	420	17		70 588 95 042
CNH CB 32 / Case CB 140						
Spitzmeissel		-	480	6		70 566 01 048
Spitzmeissel		-	580	7		70 566 01 058
Flachmeissel (quer)		45	480	6		70 566 02 048
Breitmeissel (quer)		120	440	6		70 566 70 044
Asphaltspaten (parallel)		100	450	6		70 566 43 045
Stampfwerkzeug		200 x 200	450	17		70 566 95 045
CNH CB 37						
Spitzmeissel		-	510	8		70 589 01 051
Spitzmeissel		-	700	10		70 589 01 070
Flachmeissel (quer)		50	510	8		70 589 02 051
Breitmeissel (quer)		140	480	8		70 589 18 048
Asphaltspaten (parallel)		115	490	8		70 589 83 049
Stampfwerkzeug		200 x 200	480	19		70 589 95 048
CNH CB 45 / Case CB 200						
Spitzmeissel		-	510	8		70 576 01 051
Spitzmeissel		-	750	11		70 576 01 075
Flachmeissel (quer)		50	510	8		70 576 02 051
Breitmeissel (quer)		140	480	7		70 576 18 048
Asphaltspaten (parallel)		115	490	7		70 576 83 049
Stampfwerkzeug		200 x 200	480	19		70 576 95 048

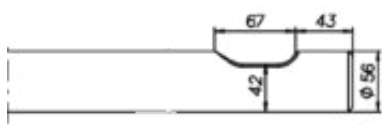
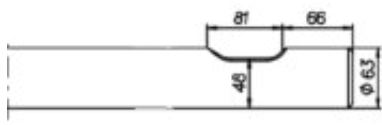
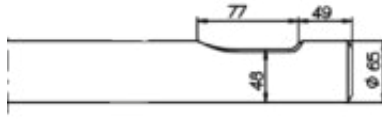
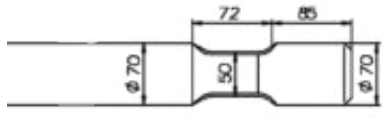
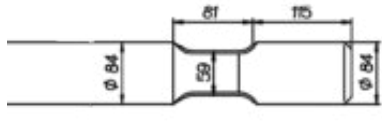
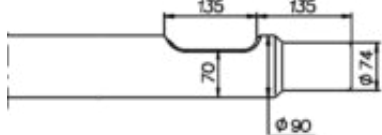



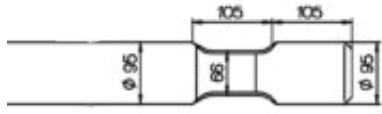
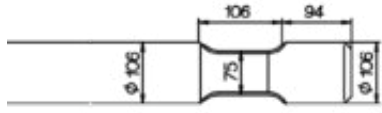

										solida - Nr.
CNH CB 65 / Case CB 370										
Spitzmeissel		-	700	16	70 565 01 070					
Spitzmeissel		-	810	19	70 565 01 081					
Flachmeissel (quer)		65	700	16	70 565 02 070					
Breitmeissel (quer)		150	550	13	70 565 34 055					
Asphaltspaten (parallel)		130	570	13	70 565 69 057					
Stampfwerkzeug		200 x 200	650	26	70 565 95 065					
CNH CB 85 / Case CB 620										
Spitzmeissel		-	740	20	70 567 01 074					
Flachmeissel (quer)		70	740	20	70 567 02 074					
Breitmeissel (quer)		150	690	20	70 567 34 069					
Asphaltspaten (parallel)		150	720	20	70 567 65 072					
Stampfwerkzeug		200 x 200	690	30	70 567 95 069					
CNH CB 90										
Spitzmeissel		-	800	28	70 592 01 080					
Flachmeissel (quer)		80	800	28	70 592 02 080					
Breitmeissel (quer)		180	760	28	70 592 22 076					
Asphaltspaten (parallel)		180	790	28	70 592 53 079					
CNH CB 120 / Case CB 735										
Spitzmeissel		-	840	33	70 577 01 084					
Flachmeissel (quer)		85	840	33	70 577 02 084					
Breitmeissel (quer)		180	840	35	70 577 22 084					
Asphaltspaten (parallel)		200	880	36	70 577 55 088					
CNH CB 150 / Case CB 1150										
Spitzmeissel		-	900	45	70 574 01 090					
Spitzmeissel		-	1000	51	70 574 01 100					
Flachmeissel (quer)		95	900	45	70 574 02 090					
Breitmeissel (quer)		200	800	42	70 574 24 080					
Asphaltspaten (parallel)		200	830	42	70 574 55 083					
Case CB 1450										
Spitzmeissel		-	1050	65	70 569 01 105					
Flachmeissel (quer)		106	1050	65	70 569 02 105					
Breitmeissel (quer)		200	1000	65	70 569 24 100					
Stampfmeissel		-	980	65	70 569 00 098					

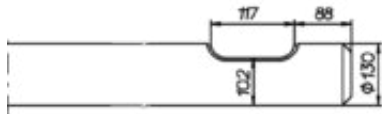
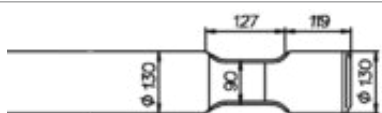
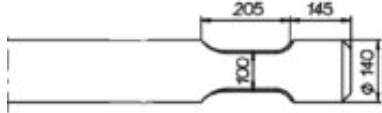
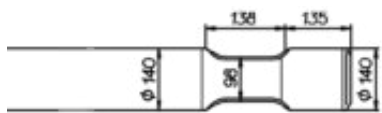
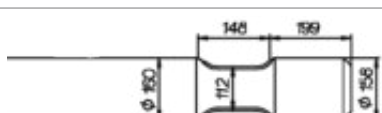
					_solida - Nr.
CNH CB 200S					
Spitzmeissel		-	1000	70	70 586 01 100
Flachmeissel (quer)		115	1000	70	70 586 02 100
Stampfmeissel		-	980	75	70 586 00 098
CNH CB 260S					
Spitzmeissel		-	1100	93	70 594 01 110
Flachmeissel (quer)		125	1100	93	70 594 02 110
Stampfmeissel		-	1020	93	70 594 00 102
CNH CB 320S / Case CB 3750					
Spitzmeissel		-	1100	101	70 571 01 110
Flachmeissel (quer)		130	1100	101	70 571 02 110
Stampfmeissel		-	1020	101	70 571 00 102
CNH CB 400S / Case CB 4000					
Spitzmeissel		-	1200	129	70 575 01 120
Flachmeissel (quer)		140	1200	129	70 575 02 120
Stampfmeissel		-	1100	129	70 575 00 110
CNH CB 550S / Case CB 5200					
Spitzmeissel		-	1400	198	70 580 01 140
Flachmeissel (quer)		160	1400	198	70 580 02 140
Stampfmeissel		-	1250	192	70 580 00 125
CNH CB 700S / Case CB 6000					
Spitzmeissel		-	1450	247	70 583 01 145
Flachmeissel (quer)		175	1450	247	70 583 02 145
Stampfmeissel		-	1350	247	70 583 00 135

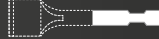
						solida - Nr.
CAT H 25 Ds						
Spitzmeissel		-	360	4		70 587 01 036
Spitzmeissel		-	600	6		70 587 01 060
Flachmeissel (quer)		42	360	4		70 587 02 036
Breitmeissel (quer)		120	350	4		70 587 70 035
Asphaltspaten (parallel)		100	380	4		70 587 43 038
CAT H 35 Ds						
Spitzmeissel		-	410	4		70 584 01 041
Spitzmeissel		-	580	6		70 584 01 058
Flachmeissel (quer)		42	410	4		70 584 02 041
Breitmeissel (quer)		120	360	4		70 584 70 036
Asphaltspaten (parallel)		100	380	4		70 584 43 038
Stampfwerkzeug		200 x 200	420	16		70 584 95 042
CAT H 45 / H 45s						
Spitzmeissel		-	480	6		70 566 01 048
Spitzmeissel		-	580	7		70 566 01 058
Flachmeissel (quer)		45	480	6		70 566 02 048
Breitmeissel (quer)		120	440	6		70 566 70 044
Asphaltspaten (parallel)		100	450	6		70 566 43 045
Stampfwerkzeug		200 x 200	450	17		70 566 95 045
CAT H 45 Ds						
Spitzmeissel		-	510	7		70 585 01 051
Spitzmeissel		-	750	11		70 585 01 075
Flachmeissel (quer)		50	510	7		70 585 02 051
Breitmeissel (quer)		140	480	7		70 585 18 048
Asphaltspaten (parallel)		115	490	7		70 585 83 049
Stampfwerkzeug		200 x 200	480	19		70 585 95 048
CAT H 50 / H 50s						
Spitzmeissel		-	510	8		70 576 01 051
Spitzmeissel		-	750	11		70 576 01 075
Flachmeissel (quer)		50	510	8		70 576 02 051
Breitmeissel (quer)		140	480	7		70 576 18 048
Asphaltspaten (parallel)		115	490	7		70 576 83 049
Stampfwerkzeug		200 x 200	480	19		70 576 95 048

						solida - Nr.
CAT H 55 Ds						
Spitzmeissel		-	580	11		70 581 01 058
Flachmeissel (quer)		57	580	11		70 581 02 058
Breitmeissel (quer)		140	550	11		70 581 18 055
Asphaltspaten (parallel)		115	560	11		70 581 83 056
Stampfwerkzeug		200 x 200	550	20		70 581 95 055
CAT H 63 / H 63s						
Spitzmeissel		-	700	16		70 565 01 070
Spitzmeissel		-	810	19		70 565 01 081
Flachmeissel (quer)		65	700	16		70 565 02 070
Breitmeissel (quer)		150	550	13		70 565 34 055
Asphaltspaten (parallel)		130	570	13		70 565 69 057
Stampfwerkzeug		200 x 200	650	26		70 565 95 065
CAT H 65 Ds						
Spitzmeissel		-	700	17		70 582 01 070
Flachmeissel (quer)		65	700	17		70 582 02 070
Breitmeissel (quer)		150	550	14		70 582 34 055
Asphaltspaten (parallel)		130	570	14		70 582 69 057
Stampfwerkzeug		200 x 200	650	27		70 582 95 065
CAT H 70 / H 70s						
Spitzmeissel		-	740	20		70 567 01 074
Flachmeissel (quer)		70	740	20		70 567 02 074
Breitmeissel (quer)		150	690	20		70 567 34 069
Asphaltspaten (parallel)		150	720	20		70 567 65 072
Stampfwerkzeug		200 x 200	690	30		70 567 95 069
CAT H 90 C / H 90 Cs						
Spitzmeissel		-	840	33		70 577 01 084
Flachmeissel (quer)		85	840	33		70 577 02 084
Breitmeissel (quer)		180	840	35		70 577 22 084
Asphaltspaten (parallel)		200	880	35		70 577 55 088
CAT H 90						
Spitzmeissel		-	890	38		70 454 01 089
Flachmeissel (quer)		90	890	38		70 454 02 089
Breitmeissel (quer)		180	840	38		70 454 22 084
Asphaltspaten (parallel)		180	870	38		70 454 53 087

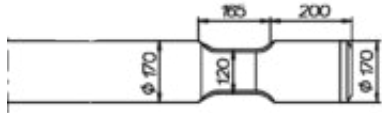
    		solida - Nr.			
CAT H 100 / H 100s					
Spitzmeissel		-	900	45	70 574 01 090
Spitzmeissel		-	1000	51	70 574 01 100
Flachmeissel (quer)		95	900	45	70 574 02 090
Breitmeissel (quer)		200	800	42	70 574 24 080
Asphaltspaten (parallel)		200	830	42	70 574 55 083
CAT H 115s / H 115 C					
Spitzmeissel		-	1050	65	70 569 01 105
Flachmeissel (quer)		106	1050	65	70 569 02 105
Breitmeissel (quer)		200	1000	65	70 569 24 100
Stampfmeissel		-	980	65	70 569 00 098
CAT H 120Cs					
Spitzmeissel		-	1060	77	70 578 01 106
Flachmeissel (quer)		115	1060	77	70 578 02 106
Stampfmeissel		-	980	77	70 578 00 098
CAT H 130					
Spitzmeissel		-	1100	103	70 561 01 110
Flachmeissel (quer)		130	1100	103	70 561 02 110
Stampfmeissel		-	1020	103	70 561 00 102
CAT H 130 C / H 130s					
Spitzmeissel		-	1100	101	70 571 01 110
Flachmeissel (quer)		130	1100	101	70 571 02 110
Stampfmeissel		-	1020	101	70 571 00 102
CAT H 140 / H 140s					
Spitzmeissel		-	1200	128	70 568 01 120
Flachmeissel (quer)		140	1200	128	70 568 02 120
Stampfmeissel		-	1100	128	70 568 00 110
CAT H 140 Cs / H 140 Ds					
Spitzmeissel		-	1200	129	70 575 01 120
Flachmeissel (quer)		140	1200	129	70 575 02 120
Stampfmeissel		-	1100	129	70 575 00 110
CAT H 160 Cs / H 160 Ds					
Spitzmeissel		-	1400	198	70 580 01 140
Flachmeissel (quer)		160	1400	198	70 580 02 140
Stampfmeissel		-	1250	192	70 580 00 125

							
CAT H 180 / H 180 C							
Spitzmeissel		-	1450	232	70 572 01 145		
Flachmeissel (quer)		170	1450	232	70 572 02 145		
Stampfmeissel		-	1350	232	70 572 00 135		
CAT H 180s / H 180 Ds							
Spitzmeissel		-	1450	247	70 583 01 145		
Flachmeissel (quer)		175	1450	247	70 583 02 145		
Stampfmeissel		-	1350	247	70 583 00 135		



Chicago Pneumatic CP 100 / RX 2

Spitzmeissel		-	410	4	70 110 01 041
Spitzmeissel		-	500	5	70 110 01 050
Flachmeissel (quer)		42	410	4	70 110 02 041
Breitmeissel (quer)		120	370	4	70 110 70 037
Asphaltspaten (parallel)		100	380	4	70 110 43 038
Stampfwerkzeug		200 x 200	380	16	70 110 95 038

Chicago Pneumatic CP 100 H / CP 75 H / CP 80 H

Spitzmeissel		-	550	7	70 503 01 055
Spitzmeissel		-	700	8	70 503 01 070
Flachmeissel (quer)		45	550	7	70 503 02 055
Breitmeissel (quer)		120	510	7	70 503 70 051
Asphaltspaten (parallel)		125	480	7	70 503 47 048
Stampfwerkzeug		200 x 200	520	17	70 503 95 052

Chicago Pneumatic CP 110 H









Spitzmeissel		-	510	7	70 510 01 051
Spitzmeissel		-	750	11	70 510 01 075
Flachmeissel (quer)		50	510	7	70 510 02 051
Breitmeissel (quer)		125	480	7	70 510 16 048
Asphaltspaten (parallel)		115	490	7	70 510 83 049
Stampfwerkzeug		200 x 200	470	18	70 510 95 047

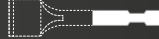





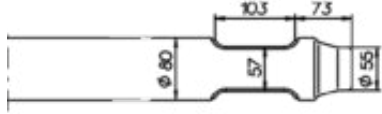

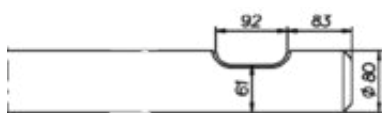
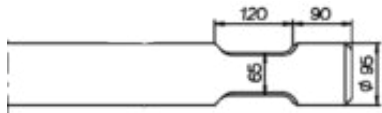





Chicago Pneumatic CP 150 / RX 3



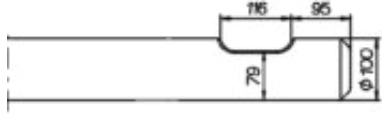

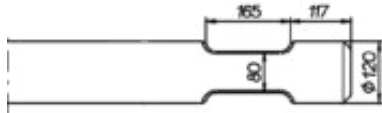

Spitzmeissel		-	530	8	70 111 01 053
Spitzmeissel		-	680	11	70 111 01 068
Flachmeissel (quer)		52	530	8	70 111 02 053
Breitmeissel (quer)		140	500	8	70 111 18 050
Asphaltspaten (parallel)		115	510	8	70 111 83 051
Stampfwerkzeug		200 x 200	500	20	70 111 95 050

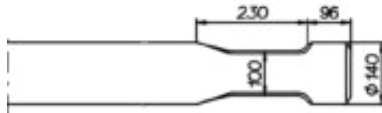
Chicago Pneumatic CP 200 / RX 4

Spitzmeissel		-	600	12	70 112 01 060
Spitzmeissel		-	750	17	70 112 01 075
Flachmeissel (quer)		62	600	12	70 112 02 060
Breitmeissel (quer)		150	550	12	70 112 34 055
Asphaltspaten (parallel)		130	570	12	70 112 69 057
Stampfwerkzeug		200 x 200	550	23	70 112 95 055

											
Chicago Pneumatic CP 180 H										solida - Nr.	
Spitzmeissel		-	600	13	70 509 01 060						
Spitzmeissel		-	800	19	70 509 01 080						
Flachmeissel (quer)		65	600	13	70 509 02 060						
Breitmeissel (quer)		125	650	16	70 509 16 065						
Asphaltspaten (parallel)		130	670	16	70 509 69 067						
Stampfwerkzeug		200 x 200	550	24	70 509 95 055						
Chicago Pneumatic CP 300 / RX 6											
Spitzmeissel		-	740	20	70 113 01 074						
Flachmeissel (quer)		70	740	20	70 113 02 074						
Breitmeissel (quer)		150	690	20	70 113 34 069						
Asphaltspaten (parallel)		150	720	20	70 113 65 072						
Stampfwerkzeug		200 x 200	690	31	70 113 95 069						
Chicago Pneumatic CP 250 H1											
Spitzmeissel		-	800	27	70 505 01 080						
Flachmeissel (quer)		80	800	27	70 505 02 080						
Breitmeissel (quer)		160	770	27	70 505 20 077						
Asphaltspaten (parallel)		180	790	27	70 505 53 079						
Chicago Pneumatic CP 290 H											
Spitzmeissel		-	800	28	70 514 01 080						
Flachmeissel (quer)		80	800	28	70 514 02 080						
Breitmeissel (quer)		160	770	28	70 514 20 077						
Asphaltspaten (parallel)		180	790	28	70 514 53 079						
Chicago Pneumatic CP 400 / CP 550 / RX 8 / RX 11											
Spitzmeissel		-	800	29	70 029 01 080						
Flachmeissel (quer)		80	800	29	70 029 02 080						
Breitmeissel (quer)		160	760	29	70 029 20 076						
Asphaltspaten (parallel)		150	790	29	70 029 65 079						
Chicago Pneumatic CP 400 H											
Spitzmeissel		-	840	41	70 511 01 084						
Flachmeissel (quer)		95	840	41	70 511 02 084						
Breitmeissel (quer)		180	800	41	70 511 22 080						
Asphaltspaten (parallel)		200	830	41	70 511 55 083						

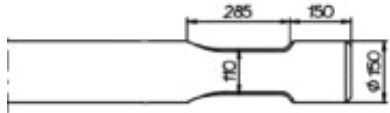
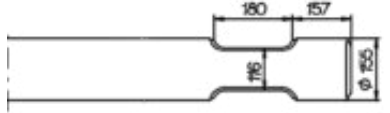
									kg	solida - Nr.
Chicago Pneumatic CP 750										
Spitzmeissel		-	1000	56	70 027 01 100					
Flachmeissel (quer)		100	1000	56	70 027 02 100					
Breitmeissel (quer)		200	950	56	70 027 24 095					
Stampfmeissel		-	930	56	70 027 00 093					
Chicago Pneumatic CP 600 H / CP 700 H / CP 900 H										
Spitzmeissel		-	900	54	70 506 01 090					
Flachmeissel (quer)		105	900	54	70 506 02 090					
Chicago Pneumatic CP 1150										
Spitzmeissel		-	1060	76	70 017 01 106					
Flachmeissel (quer)		115	1060	76	70 017 02 106					
Breitmeissel (quer)		240	1000	76	70 017 26 100					
Stampfmeissel		-	980	76	70 017 00 098					
Chicago Pneumatic RX 18										
Spitzmeissel		-	1100	87	70 028 01 110					
Flachmeissel (quer)		120	1100	87	70 028 02 110					
Stampfmeissel		-	1020	87	70 028 00 102					
Chicago Pneumatic CP 1400 H / CP 1550										
Spitzmeissel		-	1100	95	70 508 01 110					
Flachmeissel (quer)		128	1100	95	70 508 02 110					
Stampfmeissel		-	1020	95	70 508 00 102					
Chicago Pneumatic CP 1650										
Spitzmeissel		-	1100	107	70 018 01 110					
Sprengmeissel		-	1200	107	70 018 90 120					
Flachmeissel (quer)		135	1100	107	70 018 02 110					
Stampfmeissel		-	1000	107	70 018 00 100					
Chicago Pneumatic CP 1800 H / CP 2000 H										
Spitzmeissel		-	1100	108	70 507 01 110					
Flachmeissel (quer)		135	1100	108	70 507 02 110					
Stampfmeissel		-	1000	108	70 507 00 100					
Chicago Pneumatic RX 25 / RX 26										
Spitzmeissel		-	1200	128	70 026 01 120					
Flachmeissel (quer)		140	1200	128	70 026 02 120					
Stampfmeissel		-	1100	128	70 026 00 110					

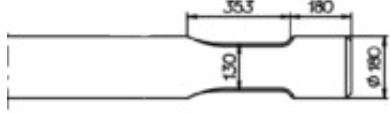
					_solida - Nr.
Chicago Pneumatic CP 2250 / RX 29 / RX 30					
Spitzmeissel		-	1300	160	70 030 01 130
Flachmeissel (quer)		150	1300	160	70 030 02 130
Stampfmeissel		-	1200	160	70 030 00 120
Chicago Pneumatic RX 38					
Spitzmeissel		-	1300	175	70 528 01 130
Flachmeissel (quer)		155	1300	175	70 528 02 130
Stampfmeissel		-	1200	175	70 528 00 120
Chicago Pneumatic CP 3050 / RX 45 / RX 46					
Spitzmeissel		-	1350	197	70 032 01 135
Flachmeissel (quer)		165	1350	197	70 032 02 135
Stampfmeissel		-	1250	197	70 032 00 125
Chicago Pneumatic CP 4250 / RX 53 / RX 54					
Spitzmeissel		-	1700	308	70 033 01 170
Flachmeissel (quer)		180	1700	308	70 033 02 170
Stampfmeissel		-	1600	308	70 033 00 160



Drago DRH 80

Spitzmeissel		-	510	7	70 701 01 051
Flachmeissel (quer)		50	510	7	70 701 02 051
Breitmeissel (quer)		140	480	7	70 701 18 048
Asphaltspaten (parallel)		115	490	7	70 701 83 049
Stampfwerkzeug		200 x 200	480	19	70 701 95 048

Drago DRH 120 bis 2011/12

Spitzmeissel		-	600	11	70 702 01 060
Flachmeissel (quer)		58	600	11	70 702 02 060
Breitmeissel (quer)		150	560	11	70 702 34 056
Asphaltspaten (parallel)		130	580	11	70 702 69 058
Stampfwerkzeug		200 x 200	560	22	70 702 95 056

Drago DRH 120 ab 2011/12









Spitzmeissel		-	600	11	70 146 01 060
Flachmeissel (quer)		58	600	11	70 146 02 060
Breitmeissel (quer)		150	560	11	70 146 34 056
Asphaltspaten (parallel)		130	580	11	70 146 69 058
Stampfwerkzeug		200 x 200	560	22	70 146 95 056

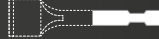



Drago DRH 150



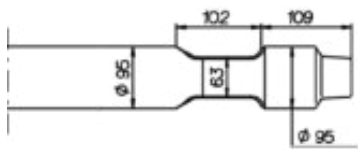
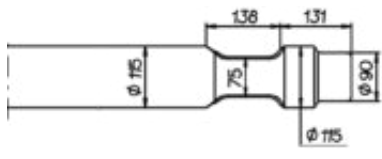
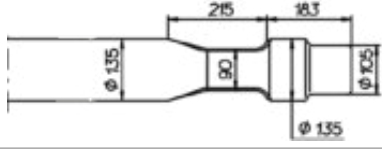
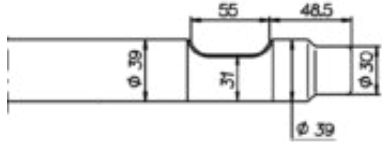
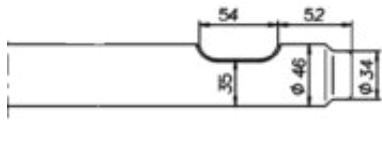
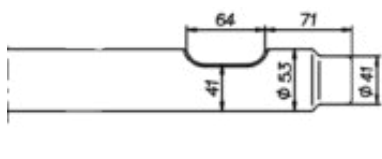



Spitzmeissel		-	700	16	70 140 01 070
Flachmeissel (quer)		65	700	16	70 140 02 070
Breitmeissel (quer)		150	650	16	70 140 34 065
Asphaltspaten (parallel)		130	670	16	70 140 69 067
Stampfwerkzeug		200 x 200	650	26	70 140 95 065

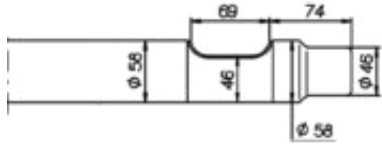
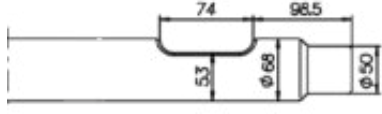
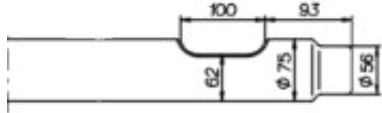
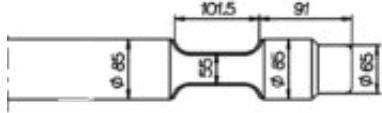
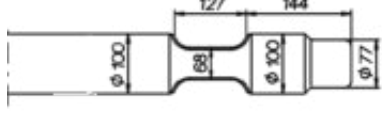

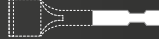

Drago DRH 180 / 250



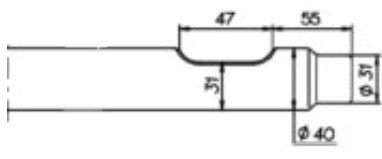
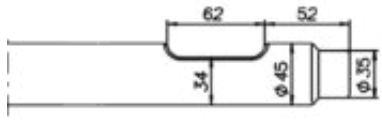
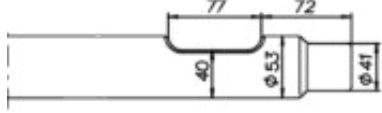
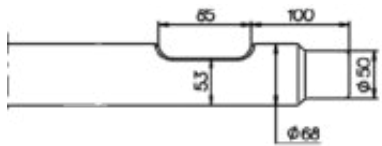
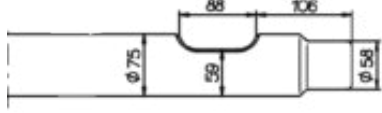

Spitzmeissel		-	720	22	70 704 01 072
Spitzmeissel		-	900	29	70 704 01 090
Flachmeissel (quer)		75	720	22	70 704 02 072
Breitmeissel (quer)		150	670	22	70 704 34 067
Asphaltspaten (parallel)		150	700	22	70 704 65 070
Stampfwerkzeug		200 x 200	670	31	70 704 95 067

									
	solida - Nr.								
Drago DRH 280									
Spitzmeissel		-	840	40	70 703 01 084				
Spitzmeissel		-	1000	49	70 703 01 100				
Flachmeissel (quer)		95	840	40	70 703 02 084				
Breitmeissel (quer)		200	800	40	70 703 24 080				
Asphaltspaten (parallel)		200	830	40	70 703 55 083				
Drago DRH 650 / 900									
Spitzmeissel		-	940	65	70 705 01 094				
Spitzmeissel		-	1060	75	70 705 01 106				
Flachmeissel (quer)		115	940	65	70 705 02 094				
Stampfmeissel		-	860	65	70 705 00 086				
Drago DRH 1150 / 1600									
Spitzmeissel		-	1200	112	70 707 01 120				
Flachmeissel (quer)		135	1200	112	70 707 02 120				
Stampfmeissel		-	1100	112	70 707 00 110				
Drago DB 10 S									
Spitzmeissel		-	450	4	70 688 01 045				
Flachmeissel (quer)		42	450	4	70 688 02 045				
Breitmeissel (quer)		120	400	4	70 688 70 040				
Asphaltspaten (parallel)		100	430	4	70 688 43 043				
Stampfwerkzeug		200 x 200	420	16	70 688 95 042				
Drago DB 15 S									
Spitzmeissel		-	510	7	70 680 01 051				
Flachmeissel (quer)		50	510	7	70 680 02 051				
Breitmeissel (quer)		125	480	7	70 680 16 048				
Asphaltspaten (parallel)		115	490	7	70 680 83 049				
Stampfwerkzeug		200 x 200	480	18	70 680 95 048				
Drago DB 20 S									
Spitzmeissel		-	600	10	70 681 01 060				
Flachmeissel (quer)		55	600	10	70 681 02 060				
Breitmeissel (quer)		140	570	10	70 681 18 057				
Asphaltspaten (parallel)		115	580	10	70 681 83 058				
Stampfwerkzeug		200 x 200	580	21	70 681 95 058				

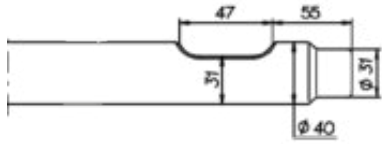
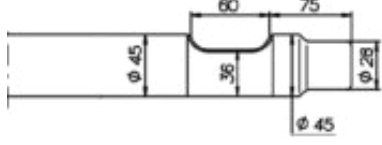
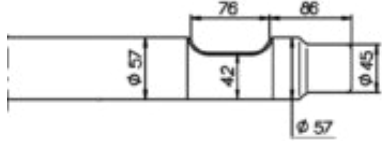
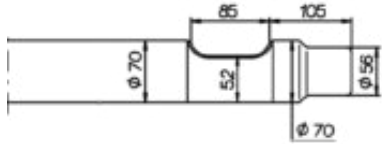
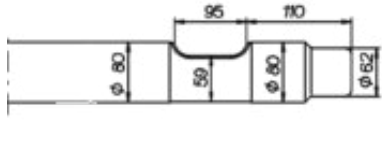
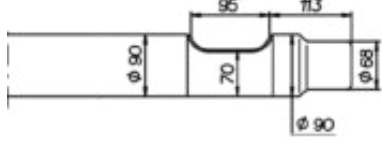
    		solida - Nr.			
Drago DB 25 S					
Spitzmeissel		-	600	11	70 687 01 060
Flachmeissel (quer)		58	600	11	70 687 02 060
Breitmeissel (quer)		150	560	11	70 687 34 056
Asphaltspaten (parallel)		130	580	11	70 687 69 058
Stampfwerkzeug		200 x 200	560	22	70 687 95 056
Drago DB 30 S					
Spitzmeissel		-	740	19	70 300 01 074
Flachmeissel (quer)		70	740	19	70 300 02 074
Breitmeissel (quer)		150	690	19	70 300 34 069
Asphaltspaten (parallel)		150	720	19	70 300 65 072
Stampfwerkzeug		200 x 200	690	28	70 300 95 069
Drago DB 35 S					
Spitzmeissel		-	820	26	70 682 01 082
Flachmeissel (quer)		75	820	26	70 682 02 082
Breitmeissel (quer)		150	750	25	70 682 34 075
Asphaltspaten (parallel)		150	780	25	70 682 65 078
Stampfwerkzeug		200 x 200	770	35	70 682 95 077
Drago DB 40 S					
Spitzmeissel		-	800	31	70 683 01 080
Flachmeissel (quer)		85	800	31	70 683 02 080
Breitmeissel (quer)		180	740	30	70 683 22 074
Asphaltspaten (parallel)		200	780	31	70 683 55 078
Drago DB 100 S					
Spitzmeissel		-	1000	52	70 684 01 100
Flachmeissel (quer)		100	1000	52	70 684 02 100
Breitmeissel (quer)		200	950	52	70 684 24 095
Stampfmeissel		-	930	52	70 684 00 093

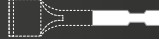
									
						kg	solida - Nr.		
Drago DBS 40									
Spitzmeissel		–	420	4	70 304 01 042				
Flachmeissel (quer)		42	420	4	70 304 02 042				
Breitmeissel (quer)		120	420	4	70 304 70 042				
Asphaltspaten (parallel)		100	420	4	70 304 43 042				
Stampfwerkzeug		200 x 200	400	16	70 304 95 040				
Drago DBS 45 / DBL 45									
Spitzmeissel		–	480	6	70 307 01 048				
Flachmeissel (quer)		45	480	6	70 307 02 048				
Breitmeissel (quer)		120	440	6	70 307 70 044				
Asphaltspaten (parallel)		100	450	6	70 307 43 045				
Stampfwerkzeug		200 x 200	450	17	70 307 95 045				
Drago DBS 53 / DBL 53									
Spitzmeissel		–	550	9	70 306 01 055				
Flachmeissel (quer)		53	550	9	70 306 02 055				
Breitmeissel (quer)		140	520	9	70 306 18 052				
Asphaltspaten (parallel)		115	530	9	70 306 83 053				
Stampfwerkzeug		200 x 200	520	20	70 306 95 052				
Drago DBS 68									
Spitzmeissel		–	740	19	70 686 01 074				
Flachmeissel (quer)		70	740	19	70 686 02 074				
Breitmeissel (quer)		150	690	19	70 686 34 069				
Asphaltspaten (parallel)		150	720	19	70 686 65 072				
Stampfwerkzeug		200 x 200	690	29	70 686 95 069				
Drago DBS 75									
Spitzmeissel		–	800	25	70 693 01 080				
Flachmeissel (quer)		75	800	25	70 693 02 080				
Breitmeissel (quer)		150	750	25	70 693 34 075				
Asphaltspaten (parallel)		150	780	25	70 693 65 078				

						solida - Nr.
D&A 7 V						
Spitzmeissel		–	420	4		70 304 01 042
Flachmeissel (quer)		42	420	4		70 304 02 042
Breitmeissel (quer)		120	420	4		70 304 70 042
Asphaltspaten (parallel)		100	420	4		70 304 43 042
Stampfwerkzeug		200 x 200	400	16		70 304 95 040
D&A 8 V						
Spitzmeissel		–	480	5		70 210 01 048
Flachmeissel (quer)		45	480	5		70 210 02 048
Breitmeissel (quer)		120	440	5		70 210 70 044
Asphaltspaten (parallel)		100	450	5		70 210 43 045
Stampfwerkzeug		200 x 200	450	17		70 210 95 045
D&A 15 V / 20 V / S 150 / S 200						
Spitzmeissel		–	580	10		70 311 01 058
Flachmeissel (quer)		57	580	10		70 311 02 058
Breitmeissel (quer)		140	550	10		70 311 18 055
Asphaltspaten (parallel)		115	560	10		70 311 83 056
Stampfwerkzeug		200 x 200	550	20		70 311 95 055
D&A 30 V / 40 V / 50 V / S 300 / S 500						
Spitzmeissel		–	740	20		70 312 01 074
Flachmeissel (quer)		70	740	20		70 312 02 074
Breitmeissel (quer)		150	690	20		70 312 34 069
Asphaltspaten (parallel)		130	710	20		70 312 69 071
Stampfwerkzeug		200 x 200	690	29		70 312 95 069
D&A 70 V / S 700						
Spitzmeissel		–	800	27		70 314 01 080
Flachmeissel (quer)		80	800	27		70 314 02 080
Breitmeissel (quer)		180	760	27		70 314 22 076
Asphaltspaten (parallel)		180	790	27		70 314 53 079
D&A 80 V / S 800						
Spitzmeissel		–	900	38		70 313 01 090
Flachmeissel (quer)		90	900	38		70 313 02 090
Breitmeissel (quer)		180	840	38		70 313 22 084
Asphaltspaten (parallel)		200	880	38		70 313 55 088

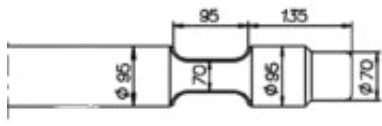
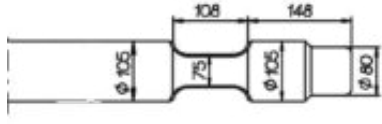
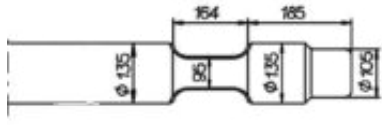
						_solida - Nr.
D&A 100 V / S 1000						
Spitzmeissel		-	950	46		70 643 01 095
Flachmeissel (quer)		95	950	46		70 643 02 095
Breitmeissel (quer)		200	910	46		70 643 24 091
Asphaltspaten (parallel)		200	940	46		70 643 55 094
D&A 130 V / S 1300						
Spitzmeissel		-	1050	62		70 315 01 105
Flachmeissel (quer)		105	1050	62		70 315 02 105
Breitmeissel (quer)		200	1000	62		70 315 24 100
Stampfmeissel		-	980	62		70 315 00 098
D&A 200 V / 220 V / S 2200						
Spitzmeissel		-	1200	114		70 317 01 120
Flachmeissel (quer)		135	1200	114		70 317 02 120
Stampfmeissel		-	1100	114		70 317 00 110



Euroram / Globram RM 45

Spitzmeißel		-	500	6	70 804 01 050
Spitzmeißel		-	700	8	70 804 01 070
Flachmeißel (quer)		45	500	6	70 804 02 050
Breitmeißel (quer)		120	460	6	70 804 70 046
Asphaltspaten (parallel)		100	470	6	70 804 43 047
Stampfwerkzeug		200 x 200	470	17	70 804 95 047

Euroram / Globram RM 48

Spitzmeißel		-	570	8	70 790 01 057
Flachmeißel (quer)		50	570	8	70 790 02 057
Breitmeißel (quer)		140	540	8	70 790 18 054
Asphaltspaten (parallel)		115	550	8	70 790 83 055
Stampfwerkzeug		200 x 200	540	19	70 790 95 054

Euroram / Globram RM 56





Spitzmeißel		-	600	10	70 791 01 060
Flachmeißel (quer)		57	600	10	70 791 02 060
Breitmeißel (quer)		140	560	10	70 791 18 056
Asphaltspaten (parallel)		115	570	10	70 791 83 057
Stampfwerkzeug		200 x 200	560	21	70 791 95 056

Euroram / Globram RM 65 / RM 70

Spitzmeißel		-	700	16	70 792 01 070
Flachmeißel (quer)		65	700	16	70 792 02 070
Breitmeißel (quer)		150	650	16	70 792 34 065
Asphaltspaten (parallel)		130	670	16	70 792 69 067
Stampfwerkzeug		200 x 200	650	26	70 792 95 065

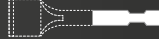
Euroram / Globram RM 75

Spitzmeißel		-	720	20	70 806 01 072
Flachmeißel (quer)		75	720	20	70 806 02 072
Breitmeißel (quer)		150	670	20	70 806 34 067
Asphaltspaten (parallel)		150	700	20	70 806 65 070
Stampfwerkzeug		200 x 200	670	30	70 806 95 067

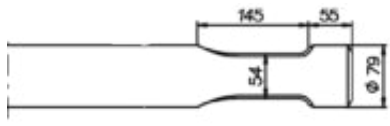
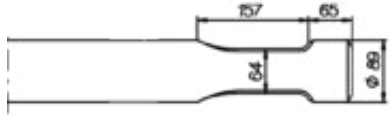
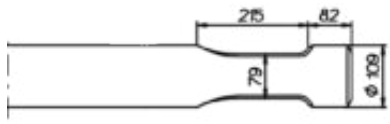
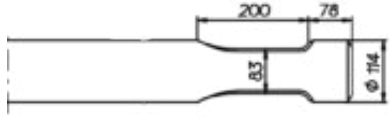
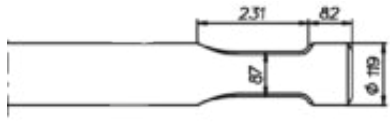
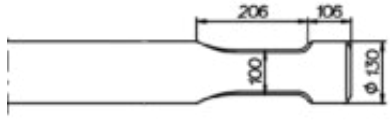
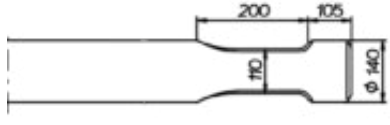
						
Euroram / Globram RM 80 / RM 82						
Spitzmeissel		–	700	23	70 793 01 070	
Flachmeissel (quer)		80	700	23	70 793 02 070	
Breitmeissel (quer)		180	660	23	70 793 22 066	
Asphaltspaten (parallel)		180	690	23	70 793 53 069	
Euroram / Globram RM 85 / RM 90						
Spitzmeissel		–	800	33	70 794 01 080	
Flachmeissel (quer)		90	800	33	70 794 02 080	
Breitmeissel (quer)		180	740	33	70 794 22 074	
Asphaltspaten (parallel)		200	790	33	70 794 55 079	
Euroram / Globram RM 110						
Spitzmeissel		–	1000	66	70 795 01 100	
Flachmeissel (quer)		114	1000	66	70 795 02 100	
Breitmeissel (quer)		240	940	66	70 795 26 094	
Stampfmeissel		–	920	66	70 795 00 092	
Euroram / Globram RM 115						
Spitzmeissel		–	1000	70	70 797 01 100	
Flachmeissel (quer)		114	1000	70	70 797 02 100	
Breitmeissel (quer)		240	940	70	70 797 26 094	
Stampfmeissel		–	920	70	70 797 00 092	
Euroram / Globram RM 120						
Spitzmeissel		–	1100	84	70 796 01 110	
Flachmeissel (quer)		120	1100	84	70 796 02 110	
Stampfmeissel		–	1020	84	70 796 00 102	
Euroram / Globram RM 130						
Spitzmeissel		–	1130	105	70 800 01 113	
Flachmeissel (quer)		130	1130	105	70 800 02 113	
Stampfmeissel		–	1100	109	70 800 00 110	
Euroram / Globram RM 140						
Spitzmeissel		–	1200	127	70 803 01 120	
Flachmeissel (quer)		140	1200	127	70 803 02 120	
Stampfmeissel		–	1100	127	70 803 00 110	



Euroram / Globram RM 145





Spitzmeissel		-	1300	147	70 798 01 130
Flachmeissel (quer)		145	1300	147	70 798 02 130
Stampfmeissel		-	1200	147	70 798 00 120

Euroram / Globram RM 150

Spitzmeissel		-	1300	161	70 805 01 130
Flachmeissel (quer)		150	1300	161	70 805 02 130
Stampfmeissel		-	1200	161	70 805 00 120

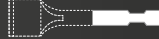
Euroram / Globram RM 160

Spitzmeissel		-	1300	176	70 799 01 130
Flachmeissel (quer)		160	1300	176	70 799 02 130
Stampfmeissel		-	1200	176	70 799 00 120

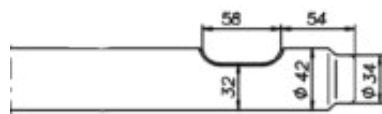
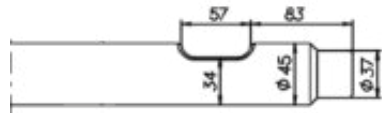
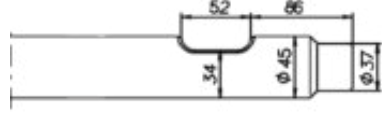
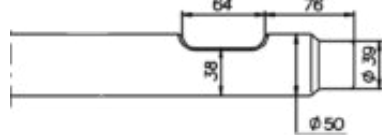
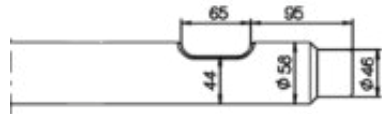
											
Everdigm EHB 008											
Spitzmeissel		–	430	4	70 932 01 043						
Flachmeissel (quer)		42	430	4	70 932 02 043						
Breitmeissel (quer)		120	380	4	70 932 70 038						
Asphaltspaten (parallel)		100	410	4	70 932 43 041						
Stampfwerkzeug		200 x 200	420	16	70 932 95 042						
Everdigm EHB 01											
Spitzmeissel		–	480	6	70 933 01 048						
Flachmeissel (quer)		45	480	6	70 933 02 048						
Breitmeissel (quer)		120	440	6	70 933 70 044						
Asphaltspaten (parallel)		100	450	6	70 933 43 045						
Stampfwerkzeug		200 x 200	450	17	70 933 95 045						
Everdigm EHB 02											
Spitzmeissel		–	480	6	70 920 01 048						
Flachmeissel (quer)		45	480	6	70 920 02 048						
Breitmeissel (quer)		120	440	6	70 920 70 044						
Asphaltspaten (parallel)		100	450	6	70 920 43 045						
Stampfwerkzeug		200 x 200	450	17	70 920 95 045						
Everdigm EHB 03											
Spitzmeissel		–	510	7	70 921 01 051						
Flachmeissel (quer)		50	510	7	70 921 02 051						
Breitmeissel (quer)		140	480	7	70 921 18 048						
Asphaltspaten (parallel)		115	490	7	70 921 83 049						
Stampfwerkzeug		200 x 200	480	19	70 921 95 048						
Everdigm EHB 04											
Spitzmeissel		–	600	11	70 922 01 060						
Flachmeissel (quer)		58	600	11	70 922 02 060						
Breitmeissel (quer)		150	560	11	70 922 34 056						
Asphaltspaten (parallel)		130	580	11	70 922 69 058						
Stampfwerkzeug		200 x 200	560	22	70 922 95 056						



Everdigm EHB 05

Spitzmeißel		-	740	19	70 923 01 074
Flachmeißel (quer)		70	740	19	70 923 02 074
Breitmeißel (quer)		150	690	19	70 923 34 069
Asphaltspaten (parallel)		150	720	19	70 923 65 072
Stampfwerkzeug		200 x 200	690	29	70 923 95 069

Everdigm EHB 06

Spitzmeißel		-	850	30	70 924 01 085
Flachmeißel (quer)		80	850	30	70 924 02 085
Breitmeißel (quer)		180	810	30	70 924 22 081
Asphaltspaten (parallel)		180	840	30	70 924 53 084

Everdigm EHB 10





Spitzmeißel		-	900	43	70 934 01 090
Flachmeißel (quer)		95	900	43	70 934 02 090
Breitmeißel (quer)		200	860	43	70 934 24 086
Asphaltspaten (parallel)		200	890	43	70 934 55 089



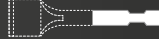

Everdigm EHB 13



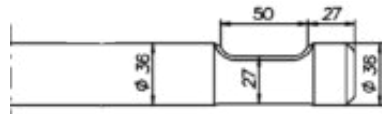
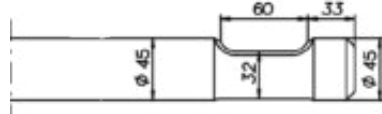
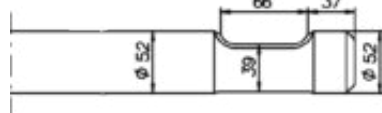
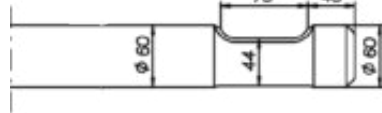
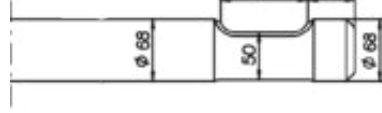
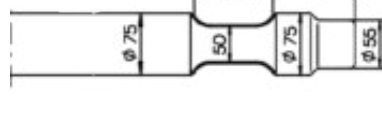

Spitzmeißel		-	1050	62	70 935 01 105
Flachmeißel (quer)		105	1050	62	70 935 02 105
Breitmeißel (quer)		200	1000	62	70 935 24 100
Stampfmeißel		-	980	62	70 935 00 098

Everdigm EHB 17

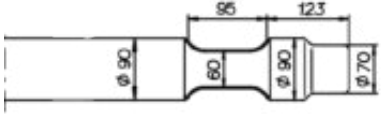
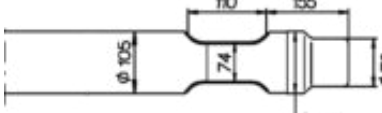
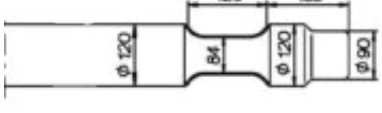
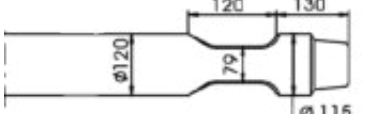
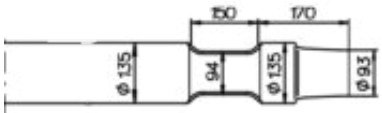
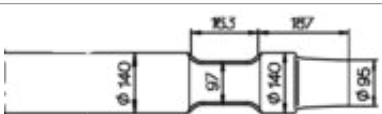
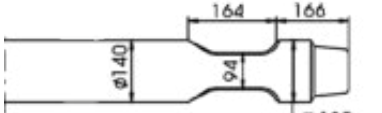
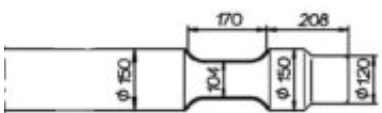
Spitzmeißel		-	1100	81	70 936 01 110
Flachmeißel (quer)		120	1100	81	70 936 02 110
Stampfmeißel		-	1000	81	70 936 00 100

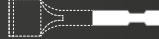
											
Furukawa F 1 / FX 15 / Kent KF 1											
Spitzmeissel		–	400	3	70 744 01 040						
Flachmeissel (quer)		42	400	3	70 744 02 040						
Breitmeissel (quer)		115	440	4	70 744 14 044						
Asphaltspaten (parallel)		125	440	4	70 744 45 044						
Stampfwerkzeug		200 x 200	380	15	70 744 95 038						
Furukawa F 2 / FX 25 / Kent KF 2											
Spitzmeissel		–	480	6	70 742 01 048						
Flachmeissel (quer)		45	480	6	70 742 02 048						
Breitmeissel (quer)		120	440	6	70 742 70 044						
Asphaltspaten (parallel)		100	450	6	70 742 43 045						
Stampfwerkzeug		200 x 200	450	17	70 742 95 045						
Furukawa F 3 / FX 35 / Kent KF 3											
Spitzmeissel		–	530	9	70 748 01 053						
Flachmeissel (quer)		55	530	9	70 748 02 053						
Breitmeissel (quer)		140	500	9	70 748 18 050						
Asphaltspaten (parallel)		115	510	9	70 748 83 051						
Stampfwerkzeug		200 x 200	500	20	70 748 95 050						
Furukawa F 4 / FX 45 / Kent KF 4											
Spitzmeissel		–	540	11	70 749 01 054						
Flachmeissel (quer)		60	540	11	70 749 02 054						
Breitmeissel (quer)		150	500	11	70 749 34 050						
Asphaltspaten (parallel)		130	520	11	70 749 69 052						
Stampfwerkzeug		200 x 200	500	22	70 749 95 050						
Furukawa F 5 / FX 55 / Kent KF 5											
Spitzmeissel		–	610	16	70 750 01 061						
Flachmeissel (quer)		70	610	16	70 750 02 061						
Breitmeissel (quer)		150	560	16	70 750 34 056						
Asphaltspaten (parallel)		150	590	16	70 750 65 059						
Stampfwerkzeug		200 x 200	690	29	70 750 95 069						
Furukawa F 6 / FX 65 / Kent KF 6											
Spitzmeissel		–	720	20	70 157 01 072						
Flachmeissel (quer)		75	720	20	70 157 02 072						
Breitmeissel (quer)		150	670	20	70 157 34 067						
Asphaltspaten (parallel)		150	700	20	70 157 65 070						
Stampfwerkzeug		200 x 200	670	30	70 157 95 067						

						solida - Nr.
Furukawa F 9 / Kent KF 9						
Spitzmeissel		-	800	33	70 158 01 080	
Flachmeissel (quer)		90	800	33	70 158 02 080	
Breitmeissel (quer)		180	740	33	70 158 22 074	
Asphaltspaten (parallel)		200	780	33	70 158 55 078	
Furukawa F 12 / Kent KF 12						
Spitzmeissel		-	1050	62	70 159 01 105	
Flachmeissel (quer)		105	1050	62	70 159 02 105	
Breitmeissel (quer)		200	1000	62	70 159 24 100	
Stampfmeissel		-	980	62	70 159 00 098	
Furukawa F 19 / Kent KF 19						
Spitzmeissel		-	1100	84	70 160 01 110	
Flachmeissel (quer)		120	1100	84	70 160 02 110	
Stampfmeissel		-	1020	84	70 160 00 102	
Furukawa FX J 175						
Spitzmeissel		-	1100	84	70 752 01 110	
Flachmeissel (quer)		120	1100	84	70 752 02 110	
Stampfmeissel		-	1020	84	70 752 00 102	
Furukawa F 20 / F 22 / Kent KF 22						
Spitzmeissel		-	1200	114	70 161 01 120	
Flachmeissel (quer)		135	1200	114	70 161 02 120	
Stampfmeissel		-	1100	114	70 161 00 110	
Furukawa F 27 / Kent KF 27						
Spitzmeissel		-	1310	134	70 751 01 131	
Flachmeissel (quer)		140	1310	134	70 751 02 131	
Stampfmeissel		-	1210	134	70 751 00 121	
Furukawa FX J 275						
Spitzmeissel		-	1350	140	70 753 01 135	
Flachmeissel (quer)		140	1350	140	70 753 02 135	
Stampfmeissel		-	1250	140	70 753 00 125	
Furukawa F 30 / F 35 / Kent KF 35						
Spitzmeissel		-	1420	170	70 162 01 142	
Flachmeissel (quer)		150	1420	170	70 162 02 142	
Stampfmeissel		-	1320	170	70 162 00 132	

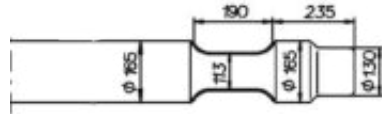
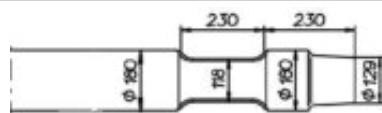
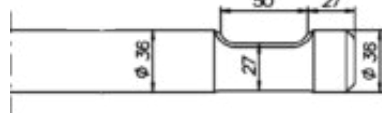
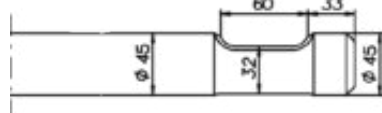
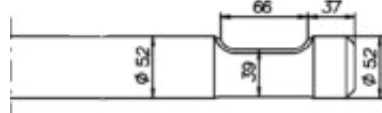
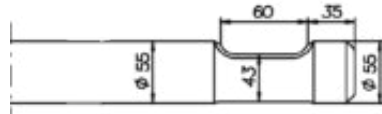
							solida - Nr.
Furukawa F 45 / Kent KF 45							
Spitzmeißel		-	1450	215	-	70 163 01 145	
Flachmeißel (quer)		170	1450	215	-	70 163 02 145	
Stampfmeißel		-	1350	215	-	70 163 00 135	
Furukawa F 70 / Kent KF 70							
Spitzmeißel		-	1600	277	-	70 164 01 160	
Flachmeißel (quer)		180	1600	277	-	70 164 02 160	
Stampfmeißel		-	1500	277	-	70 164 00 150	
Furukawa HB 1 G / Kent KHB 1 G							
Spitzmeißel		-	400	3	-	70 744 01 040	
Flachmeißel (quer)		42	400	3	-	70 744 02 040	
Breitmeißel (quer)		115	440	4	-	70 744 14 044	
Asphaltspaten (parallel)		125	440	4	-	70 744 45 044	
Stampfwerkzeug		200 x 200	380	15	-	70 744 95 038	
Furukawa HB 2 G / Kent KHB 20 / KHB 2GII							
Spitzmeißel		-	480	6	-	70 742 01 048	
Flachmeißel (quer)		45	480	6	-	70 742 02 048	
Breitmeißel (quer)		120	440	6	-	70 742 70 044	
Asphaltspaten (parallel)		100	450	6	-	70 742 43 045	
Stampfwerkzeug		200 x 200	450	18	-	70 742 95 045	
Furukawa HB 2,5 G / HB 3 R							
Spitzmeißel		-	530	9	-	70 748 01 053	
Flachmeißel (quer)		55	530	9	-	70 748 02 053	
Breitmeißel (quer)		140	500	9	-	70 748 18 050	
Asphaltspaten (parallel)		115	510	9	-	70 748 83 051	
Stampfwerkzeug		200 x 200	500	21	-	70 748 95 050	
Furukawa HB 100							
Spitzmeißel		-	530	9	-	70 730 01 053	
Flachmeißel (quer)		55	530	9	-	70 730 02 053	
Breitmeißel (quer)		140	500	9	-	70 730 18 050	
Asphaltspaten (parallel)		115	510	9	-	70 730 83 051	
Stampfwerkzeug		200 x 200	500	21	-	70 730 95 050	



Furukawa HB 3 G / Kent KHB 30 / KHB 3 GII

Spitzmeissel		-	540	11	70 749 01 054
Flachmeissel (quer)		60	540	11	70 749 02 054
Breitmeissel (quer)		150	500	11	70 749 34 050
Asphaltspaten (parallel)		130	520	11	70 749 69 052
Stampfwerkzeug		200 x 200	500	23	70 749 95 050

Furukawa HB 200

Spitzmeissel		-	740	20	70 731 01 074
Flachmeissel (quer)		70	740	20	70 731 02 074
Breitmeissel (quer)		150	690	20	70 731 34 069
Asphaltspaten (parallel)		150	720	20	70 731 65 072
Stampfwerkzeug		200 x 200	690	32	70 731 95 069

Furukawa HB 5 G / Kent KHB 50 / KHB 5 GII

Spitzmeissel		-	720	22	70 743 01 072
Flachmeissel (quer)		75	720	22	70 743 02 072
Breitmeissel (quer)		150	670	22	70 743 34 067
Asphaltspaten (parallel)		150	700	22	70 743 65 070
Stampfwerkzeug		200 x 200	670	34	70 743 95 067

Furukawa HB 8 G / Kent KHB 80 / KHB 8 GII



Spitzmeissel		-	800	35	70 746 01 080
Flachmeissel (quer)		90	800	35	70 746 02 080
Breitmeissel (quer)		180	740	35	70 746 22 074
Asphaltspaten (parallel)		200	780	35	70 746 55 078





Furukawa HB 10 G / Kent KHB 100 / KHB 10 GII / -HD

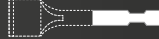

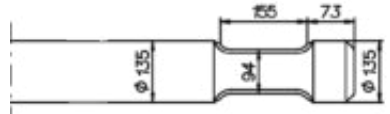
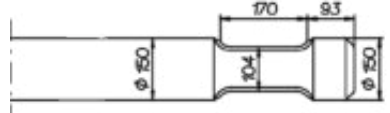
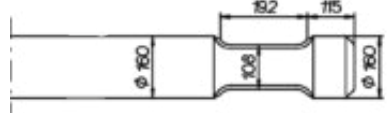

Spitzmeissel		-	970	60	70 739 01 097
Flachmeissel (quer)		105	970	60	70 739 02 097
Breitmeissel (quer)		200	920	60	70 739 24 092

Furukawa HB 15 G / Kent KHB 150 / KHB 15 GII

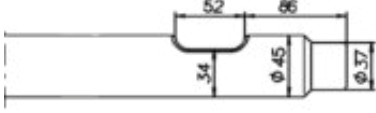
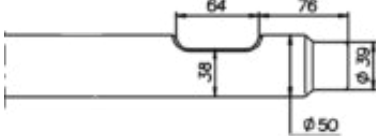
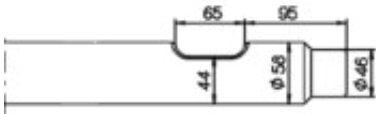
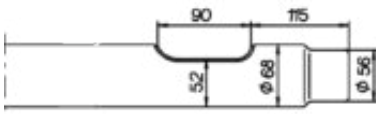
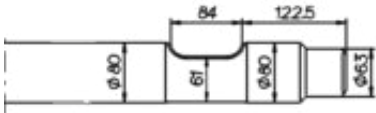
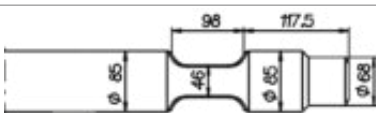
Spitzmeissel		-	1000	79	70 737 01 100
Flachmeissel (quer)		120	1000	79	70 737 02 100
Stampfmeissel		-	920	79	70 737 00 092

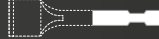
						_solida - Nr.
Furukawa HB 20 G / Kent KHB 200 / KHB 20 GII						
Spitzmeissel		-	1200	118	70 738 01 120	
Flachmeissel (quer)		135	1200	118	70 738 02 120	
Stampfmeissel		-	1100	118	70 738 00 110	
Furukawa HB 30 G / Kent KHB 300 / KHB 30 GII						
Spitzmeissel		-	1300	157	70 740 01 130	
Flachmeissel (quer)		150	1300	157	70 740 02 130	
Stampfmeissel		-	1200	157	70 740 00 120	
Furukawa HB 40 G / Kent KHB 400 / KHB 40 GII						
Spitzmeissel		-	1300	180	70 741 01 130	
Flachmeissel (quer)		160	1300	180	70 741 02 130	
Stampfmeissel		-	1200	180	70 741 00 120	

						solida - Nr.
Hanwoo RHB 302 V						
Spitzmeissel		-	480	6		70 920 01 048
Flachmeissel (quer)		45	480	6		70 920 02 048
Breitmeissel (quer)		120	440	6		70 920 70 044
Asphaltspaten (parallel)		100	450	6		70 920 43 045
Stampfwerkzeug		200 x 200	450	17		70 920 95 045
Hanwoo RHB 302 / 303 V						
Spitzmeissel		-	510	7		70 921 01 051
Flachmeissel (quer)		50	510	7		70 921 02 051
Breitmeissel (quer)		140	480	7		70 921 18 048
Asphaltspaten (parallel)		115	490	7		70 921 83 049
Stampfwerkzeug		200 x 200	480	19		70 921 95 048
Hanwoo RHB 304						
Spitzmeissel		-	600	11		70 922 01 060
Flachmeissel (quer)		58	600	11		70 922 02 060
Breitmeissel (quer)		150	560	11		70 922 34 056
Asphaltspaten (parallel)		130	580	11		70 922 69 058
Stampfwerkzeug		200 x 200	560	22		70 922 95 056
Hanwoo RHB 305 V						
Spitzmeissel		-	740	19		70 923 01 074
Flachmeissel (quer)		70	740	19		70 923 02 074
Breitmeissel (quer)		150	690	19		70 923 34 069
Asphaltspaten (parallel)		150	720	19		70 923 65 072
Stampfwerkzeug		200 x 200	690	29		70 923 95 069
Hanwoo RHB 306						
Spitzmeissel		-	850	30		70 924 01 085
Flachmeissel (quer)		80	850	30		70 924 02 085
Breitmeissel (quer)		180	810	30		70 924 22 081
Asphaltspaten (parallel)		180	840	30		70 924 53 084
Hanwoo RHB 308 V / 309						
Spitzmeissel		-	890	34		70 925 01 089
Flachmeissel (quer)		85	890	34		70 925 02 089

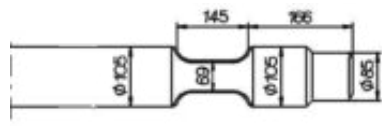
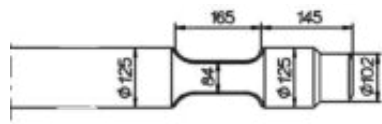
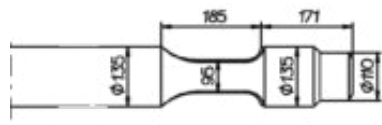
						_solida - Nr.
Hanwoo RHB 313 V						
Spitzmeissel		-	1050	62		70 926 01 105
Flachmeissel (quer)		105	1050	62		70 926 02 105
Breitmeissel (quer)		200	1000	62		70 926 24 100
Stampfmeissel		-	980	62		70 926 00 098
Hanwoo RHB 320						
Spitzmeissel		-	1150	98		70 927 01 115
Flachmeissel (quer)		125	1150	98		70 927 02 115
Stampfmeissel		-	1050	98		70 927 00 105
Hanwoo RHB 322 V / 323 / 325						
Spitzmeissel		-	1200	114		70 928 01 120
Flachmeissel (quer)		135	1200	114		70 928 02 120
Stampfmeissel		-	1100	114		70 928 00 110



				kg	solida - Nr.
Huppi 52					
Spitzmeissel		-	450	4	70 142 01 045
Flachmeissel (quer)		42	450	4	70 142 02 045
Breitmeissel (quer)		120	410	4	70 142 70 041
Asphaltspaten (parallel)		100	420	4	70 142 43 042
Stampfwerkzeug		200 x 200	450	16	70 142 95 045
Huppi 72					
Spitzmeissel		-	480	5	70 143 01 048
Flachmeissel (quer)		45	480	5	70 143 02 048
Breitmeissel (quer)		120	440	5	70 143 70 044
Asphaltspaten (parallel)		100	450	5	70 143 43 045
Stampfwerkzeug		200 x 200	450	17	70 143 95 045
Huppi 102					
Spitzmeissel		-	600	11	70 702 01 060
Flachmeissel (quer)		58	600	11	70 702 02 060
Breitmeissel (quer)		150	560	11	70 702 34 056
Asphaltspaten (parallel)		130	580	11	70 702 69 058
Stampfwerkzeug		200 x 200	560	22	70 702 95 056
Huppi 102 (neu)					
Spitzmeissel		-	600	11	70 146 01 060
Flachmeissel (quer)		58	600	11	70 146 02 060
Breitmeissel (quer)		150	560	11	70 146 34 056
Asphaltspaten (parallel)		130	580	11	70 146 69 058
Stampfwerkzeug		200 x 200	560	22	70 146 95 056
Huppi 302					
Spitzmeissel		-	720	22	70 704 01 072
Flachmeissel (quer)		75	720	22	70 704 02 072
Breitmeissel (quer)		150	670	22	70 704 34 067
Asphaltspaten (parallel)		150	700	22	70 704 65 070
Stampfwerkzeug		200 x 200	670	30	70 704 95 067
Huppi 402					
Spitzmeissel		-	840	40	70 703 01 084
Flachmeissel (quer)		95	840	40	70 703 02 084
Breitmeissel (quer)		200	800	40	70 703 24 080
Asphaltspaten (parallel)		200	830	40	70 703 55 083



Huppi 902

Spitzmeissel		-	940	65	70 705 01 094
Flachmeissel (quer)		115	940	65	70 705 02 094
Stampfmeissel		-	860	65	70 705 00 086



Indeco HP 150 / MES 121 / 150

Spitzmeißel		-	500	6	70 804 01 050
Spitzmeißel		-	700	8	70 804 01 070
Flachmeißel (quer)		45	500	6	70 804 02 050
Breitmeißel (quer)		120	460	6	70 804 70 046
Asphaltspaten (parallel)		100	470	6	70 804 43 047
Stampfwerkzeug		200 x 200	470	18	70 804 95 047

Indeco HP 200 / MES 180 / 181 / 200 / 250 / UP 181 / 200

Spitzmeißel		-	570	8	70 790 01 057
Flachmeißel (quer)		50	570	8	70 790 02 057
Breitmeißel (quer)		140	540	8	70 790 18 054
Asphaltspaten (parallel)		115	550	8	70 790 83 055
Stampfwerkzeug		200 x 200	540	19	70 790 95 054

Indeco HP 350 / MES 300 / 301 / 350 / 351 / UP 301 / 350 / 351





Spitzmeißel		-	600	10	70 791 01 060
Flachmeißel (quer)		57	600	10	70 791 02 060
Breitmeißel (quer)		140	560	10	70 791 18 056
Asphaltspaten (parallel)		115	570	10	70 791 83 057
Stampfwerkzeug		200 x 200	560	20	70 791 95 056





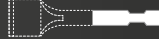

Indeco HB 5 / HP 500 / MES 450 / 451 / 521 / 550 / UP 462 / 521 / 550

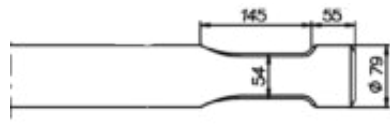
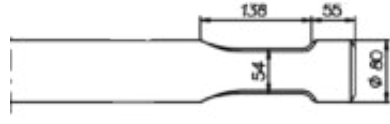
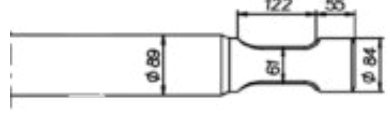
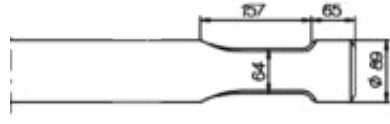
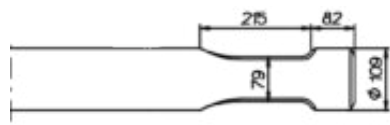
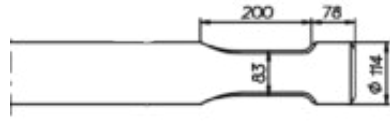
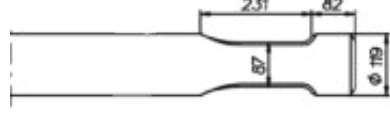



Spitzmeißel		-	700	16	70 792 01 070
Flachmeißel (quer)		65	700	16	70 792 02 070
Breitmeißel (quer)		150	650	16	70 792 34 065
Asphaltspaten (parallel)		130	670	16	70 792 69 067
Stampfwerkzeug		200 x 200	650	27	70 792 95 065

Indeco HP 600 / MES 553 / UP 553

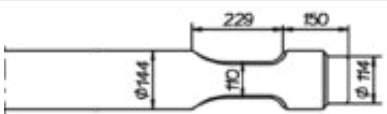
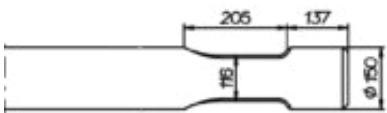
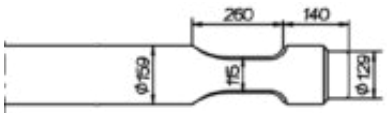
Spitzmeißel		-	720	20	70 806 01 072
Flachmeißel (quer)		75	720	20	70 806 02 072
Breitmeißel (quer)		150	670	20	70 806 34 067
Asphaltspaten (parallel)		150	700	20	70 806 65 070
Stampfwerkzeug		200 x 200	670	30	70 806 95 067

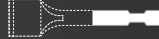
						solida - Nr.
Indeco HB 8						
Spitzmeissel		–	700	23		70 793 01 070
Flachmeissel (quer)		80	700	23		70 793 02 070
Breitmeissel (quer)		180	660	23		70 793 22 066
Asphaltspaten (parallel)		180	690	23		70 793 53 069
Indeco HP 700 / MES 601 / 621 / 650 / UP 601 / 621 / 650						
Spitzmeissel		–	700	24		70 801 01 070
Flachmeissel (quer)		80	700	24		70 801 02 070
Breitmeissel (quer)		180	660	24		70 801 22 066
Asphaltspaten (parallel)		180	690	24		70 801 53 069
Indeco HP 900						
Spitzmeissel		–	800	33		70 810 01 080
Flachmeissel (quer)		90	800	33		70 810 02 080
Breitmeissel (quer)		180	740	33		70 810 22 074
Asphaltspaten (parallel)		200	780	33		70 810 55 078
Indeco HB 12 / HP 1200 / MES 1050 / 1200 / UP 1200						
Spitzmeissel		–	800	33		70 794 01 080
Flachmeissel (quer)		90	800	33		70 794 02 080
Breitmeissel (quer)		180	740	33		70 794 22 074
Asphaltspaten (parallel)		200	790	33		70 794 55 079
Indeco HB 19 / MES 1500						
Spitzmeissel		–	1000	66		70 795 01 100
Flachmeissel (quer)		110	1000	66		70 795 02 100
Breitmeissel (quer)		200	940	66		70 795 26 094
Stampfmeissel		–	920	66		70 795 00 092
Indeco MES 1800 / MES 1750						
Spitzmeissel		–	1000	70		70 797 01 100
Flachmeissel (quer)		115	1000	70		70 797 02 100
Breitmeissel (quer)		200	940	70		70 797 26 094
Stampfmeissel		–	920	70		70 797 00 092
Indeco HB 27 / MES 2000						
Spitzmeissel		–	1100	84		70 796 01 110
Flachmeissel (quer)		120	1100	84		70 796 02 110
Stampfmeissel		–	1020	84		70 796 00 102

					solida - Nr.
Indeco MES 2500					
Spitzmeissel		-	1130	105	70 800 01 113
Flachmeissel (quer)		130	1130	105	70 800 02 113
Stampfmeissel		-	1100	109	70 800 00 110
Indeco MES 3000					
Spitzmeissel		-	1200	127	70 803 01 120
Flachmeissel (quer)		140	1200	127	70 803 02 120
Stampfmeissel		-	1100	127	70 803 00 110
Indeco MES 3500					
Spitzmeissel		-	1300	147	70 798 01 130
Flachmeissel (quer)		145	1300	147	70 798 02 130
Stampfmeissel		-	1200	147	70 798 00 120
Indeco MES 4000					
Spitzmeissel		-	1300	161	70 805 01 130
Flachmeissel (quer)		150	1300	161	70 805 02 130
Stampfmeissel		-	1200	161	70 805 00 120
Indeco MES 5000					
Spitzmeissel		-	1300	176	70 799 01 130
Flachmeissel (quer)		160	1300	176	70 799 02 130
Stampfmeissel		-	1200	176	70 799 00 120

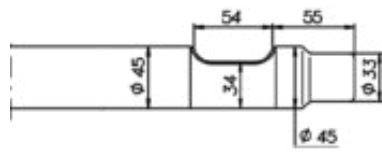
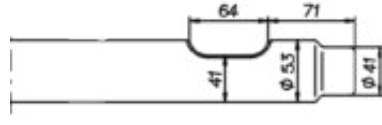
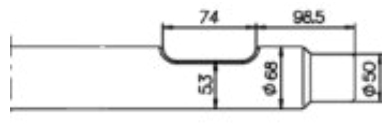
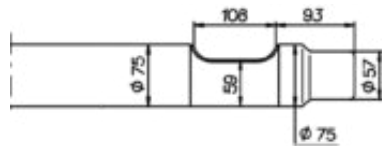
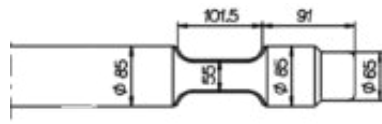
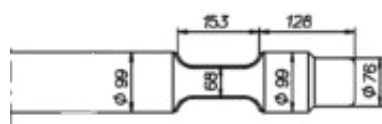
							solida - Nr.
JAB JB 8				-	500	6	70 180 01 050
Spitzmeissel	-			500	6	70 180 01 050	
Flachmeissel (quer)	45			500	6	70 180 02 050	
Breitmeissel (quer)	120			460	6	70 180 70 046	
Asphaltspaten (parallel)	100			470	6	70 180 43 047	
Stampfwerkzeug	200 x 200	470	17	70 180 95 047			
JAB JB 10				-	600	10	70 681 01 060
Spitzmeissel	-			600	10	70 681 01 060	
Flachmeissel (quer)	55			600	10	70 681 02 060	
Breitmeissel (quer)	140			570	10	70 681 18 057	
Asphaltspaten (parallel)	115			580	10	70 681 83 058	
Stampfwerkzeug	200 x 200	580	21	70 681 95 058			
JAB JB 20				-	740	19	70 300 01 074
Spitzmeissel	-			740	19	70 300 01 074	
Flachmeissel (quer)	70			740	19	70 300 02 074	
Breitmeissel (quer)	150			690	19	70 300 34 069	
Asphaltspaten (parallel)	150			720	19	70 300 65 072	
Stampfwerkzeug	200 x 200	690	28	70 300 95 069			
JAB JB 30				-	720	21	70 183 01 072
Spitzmeissel	-			720	21	70 183 01 072	
Flachmeissel (quer)	75			720	21	70 183 02 072	
Breitmeissel (quer)	150			670	21	70 183 34 067	
Asphaltspaten (parallel)	150			700	21	70 183 65 070	
Stampfwerkzeug	200 x 200	670	30	70 183 95 067			
JAB JB 40				-	800	31	70 683 01 080
Spitzmeissel	-			800	31	70 683 01 080	
Flachmeissel (quer)	85			800	31	70 683 02 080	
Breitmeissel (quer)	180			740	30	70 683 22 074	
Asphaltspaten (parallel)	200	780	31	70 683 55 078			
JAB JB 60				-	1000	52	70 182 01 100
Spitzmeissel	-			1000	52	70 182 01 100	
Flachmeissel (quer)	100			1000	52	70 182 02 100	
Breitmeissel (quer)	200			950	52	70 182 24 095	
Stampfmeissel	-	930	52	70 182 00 093			



JAB JB 70









Spitzmeissel		-	1100	86	70 185 01 110
Flachmeissel (quer)		120	1100	86	70 185 02 110
Stampfmeissel		-	1020	86	70 185 00 102

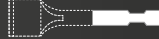



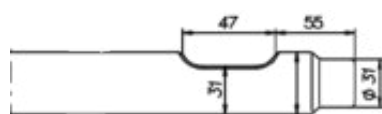

JAB JB 71

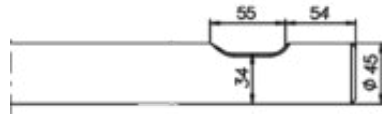
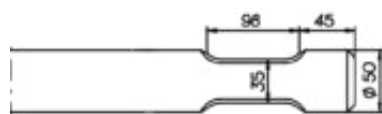



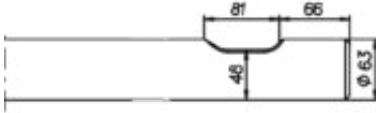
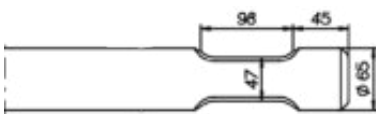
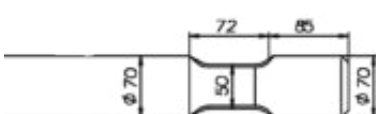

Spitzmeissel		-	1100	92	70 184 01 110
Flachmeissel (quer)		125	1100	92	70 184 02 110
Stampfmeissel		-	1020	92	70 184 00 102

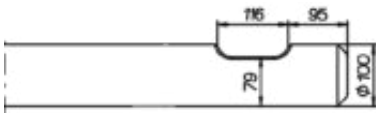

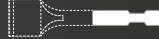

JAB JB 80

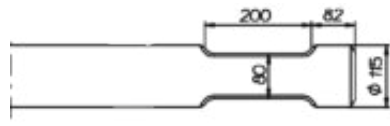
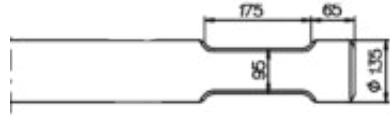
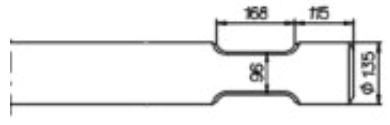
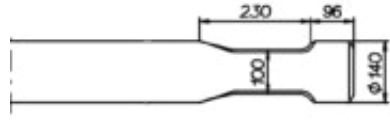
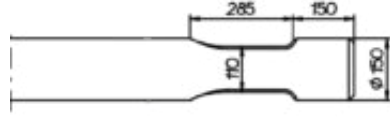

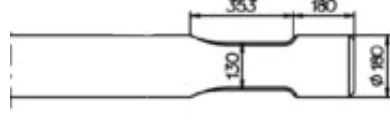

Spitzmeissel		-	1200	118	70 181 01 120
Flachmeissel (quer)		135	1200	118	70 181 02 120
Stampfmeissel		-	1100	118	70 181 00 110

								
JCB HM 65								
Spitzmeissel		-	430	4	70 612 01 043			
Flachmeissel (quer)		42	430	4	70 612 02 043			
Breitmeissel (quer)		120	410	4	70 612 70 041			
Asphaltspaten (parallel)		100	420	4	70 612 43 042			
Stampfwerkzeug		200 x 200	420	16	70 612 95 042			
JCB HM 80								
Spitzmeissel		-	420	4	70 304 01 042			
Flachmeissel (quer)		42	420	4	70 304 02 042			
Breitmeissel (quer)		120	420	4	70 304 70 042			
Asphaltspaten (parallel)		100	420	4	70 304 43 042			
Stampfwerkzeug		200 x 200	400	16	70 304 95 040			
JCB HM 100 / HM 100 Q / HM 115								
Spitzmeissel		-	500	6	70 611 01 050			
Flachmeissel (quer)		45	500	6	70 611 02 050			
Breitmeissel (quer)		120	460	6	70 611 70 046			
Asphaltspaten (parallel)		100	470	6	70 611 43 047			
Stampfwerkzeug		200 x 200	470	18	70 611 95 047			
JCB HM 160 / HM 160 Q								
Spitzmeissel		-	480	6	70 566 01 048			
Spitzmeissel		-	580	7	70 566 01 058			
Flachmeissel (quer)		45	480	6	70 566 02 048			
Breitmeissel (quer)		120	440	6	70 566 70 044			
Asphaltspaten (parallel)		100	450	6	70 566 43 045			
Stampfwerkzeug		200 x 200	450	17	70 566 95 045			
JCB HM 165 Q / HM 166 Q								
Spitzmeissel		-	510	7	70 510 01 051			
Spitzmeissel		-	750	11	70 510 01 075			
Flachmeissel (quer)		50	510	7	70 510 02 051			
Breitmeissel (quer)		125	480	7	70 510 16 048			
Asphaltspaten (parallel)		115	490	7	70 510 83 049			
Stampfwerkzeug		200 x 200	470	18	70 510 95 047			

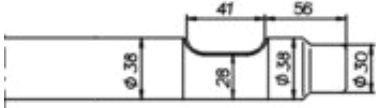
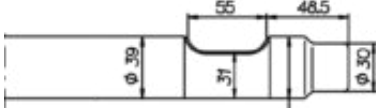
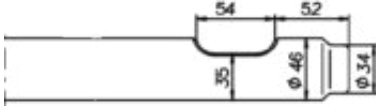
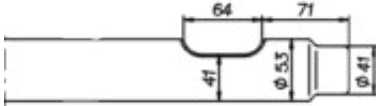
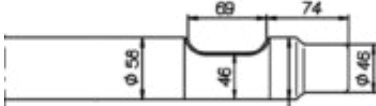
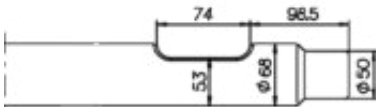
    		solida - Nr.			
JCB HM 260 / HM 260 Q					
Spitzmeissel		-	700	16	70 565 01 070
Spitzmeissel		-	810	18	70 565 01 081
Flachmeissel (quer)		65	700	16	70 565 02 070
Breitmeissel (quer)		150	550	13	70 565 34 055
Asphaltspaten (parallel)		130	570	13	70 565 69 057
Stampfwerkzeug		200 x 200	650	26	70 565 95 065
JCB HM 265 Q / HM 266 Q					
Spitzmeissel		-	600	13	70 509 01 060
Spitzmeissel		-	800	19	70 509 01 080
Flachmeissel (quer)		65	600	13	70 509 02 060
Breitmeissel (quer)		125	650	16	70 509 16 065
Asphaltspaten (parallel)		130	670	16	70 509 69 067
Stampfwerkzeug		200 x 200	550	24	70 509 95 055
JCB HM 360 / HM 360 Q					
Spitzmeissel		-	740	20	70 567 01 074
Flachmeissel (quer)		70	740	20	70 567 02 074
Breitmeissel (quer)		150	690	20	70 567 34 069
Asphaltspaten (parallel)		150	720	20	70 567 65 072
Stampfwerkzeug		200 x 200	690	30	70 567 95 069
JCB HM 385 Q / HM 386 Q					
Spitzmeissel		-	800	28	70 514 01 080
Flachmeissel (quer)		80	800	28	70 514 02 080
Breitmeissel (quer)		160	770	28	70 514 20 077
Asphaltspaten (parallel)		180	790	28	70 514 53 079
JCB HM 495 Q / HM 496 Q					
Spitzmeissel		-	840	41	70 511 01 084
Flachmeissel (quer)		95	840	41	70 511 02 084
Breitmeissel (quer)		180	800	41	70 511 22 080
Asphaltspaten (parallel)		200	830	41	70 511 55 083
JCB HM 860 Q					
Spitzmeissel		-	1000	56	70 027 01 100
Flachmeissel (quer)		100	1000	56	70 027 02 100
Breitmeissel (quer)		200	950	56	70 027 24 095
Stampfmeissel		-	930	56	70 027 00 093

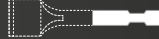
						_solida - Nr.
JCB HM 1260 Q						
Spitzmeissel		–	1060	76	70 017 01 106	
Flachmeissel (quer)		115	1060	76	70 017 02 106	
Breitmeissel (quer)		240	1000	76	70 017 26 100	
Stampfmeissel		–	980	76	70 017 00 098	
JCB HM 1560 Q						
Spitzmeissel		–	1100	107	70 018 01 110	
Sprengmeissel		–	1200	107	70 018 90 120	
Flachmeissel (quer)		135	1100	107	70 018 02 110	
Stampfmeissel		–	1000	107	70 018 00 100	
JCB HM 1570 Q						
Spitzmeissel		–	1200	118	70 525 01 120	
Flachmeissel (quer)		135	1200	118	70 525 02 120	
Stampfmeissel		–	1100	118	70 525 00 110	
JCB HM 1760 Q						
Spitzmeissel		–	1200	128	70 026 01 120	
Flachmeissel (quer)		140	1200	128	70 026 02 120	
Stampfmeissel		–	1100	128	70 026 00 110	
JCB HM 2460 Q						
Spitzmeissel		–	1300	160	70 030 01 130	
Flachmeissel (quer)		150	1300	160	70 030 02 130	
Stampfmeissel		–	1200	160	70 030 00 120	
JCB HM 3060 Q						
Spitzmeissel		–	1350	197	70 032 01 135	
Flachmeissel (quer)		165	1350	197	70 032 02 135	
Stampfmeissel		–	1250	197	70 032 00 125	
JCB HM 4160 Q						
Spitzmeissel		–	1700	308	70 033 01 170	
Flachmeissel (quer)		180	1700	308	70 033 02 170	
Stampfmeissel		–	1600	308	70 033 00 160	

										solida - Nr.	
Komac KB 90											
Spitzmeissel		–	410	4	70 685 01 041						
Flachmeissel (quer)		42	410	4	70 685 02 041						
Breitmeissel (quer)		120	360	4	70 685 70 036						
Asphaltspaten (parallel)		100	390	4	70 685 43 039						
Stampfwerkzeug		200 x 200	420	16	70 685 95 042						
Komac KB 100											
Spitzmeissel		–	450	4	70 688 01 045						
Flachmeissel (quer)		42	450	4	70 688 02 045						
Breitmeissel (quer)		120	400	4	70 688 70 040						
Asphaltspaten (parallel)		100	430	4	70 688 43 043						
Stampfwerkzeug		200 x 200	420	16	70 688 95 042						
Komac KB 150											
Spitzmeissel		–	510	7	70 680 01 051						
Flachmeissel (quer)		50	510	7	70 680 02 051						
Breitmeissel (quer)		125	480	7	70 680 16 048						
Asphaltspaten (parallel)		115	490	7	70 680 83 049						
Stampfwerkzeug		200 x 200	480	18	70 680 95 048						
Komac KB 200											
Spitzmeissel		–	600	10	70 681 01 060						
Flachmeissel (quer)		55	600	10	70 681 02 060						
Breitmeissel (quer)		140	570	10	70 681 18 057						
Asphaltspaten (parallel)		115	580	10	70 681 83 058						
Stampfwerkzeug		200 x 200	580	21	70 681 95 058						
Komac KB 250											
Spitzmeissel		–	600	11	70 687 01 060						
Flachmeissel (quer)		58	600	11	70 687 02 060						
Breitmeissel (quer)		150	560	11	70 687 34 056						
Asphaltspaten (parallel)		130	580	11	70 687 69 058						
Stampfwerkzeug		200 x 200	560	22	70 687 95 056						
Komac KB 300											
Spitzmeissel		–	740	19	70 300 01 074						
Flachmeissel (quer)		70	740	19	70 300 02 074						
Breitmeissel (quer)		150	690	19	70 300 34 069						
Asphaltspaten (parallel)		150	720	19	70 300 65 072						
Stampfwerkzeug		200 x 200	690	29	70 300 95 069						

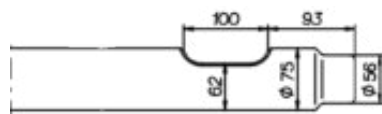
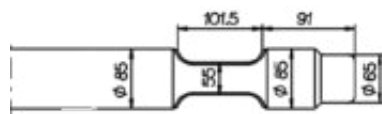
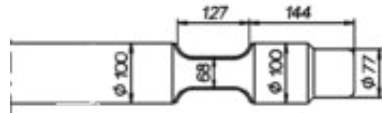
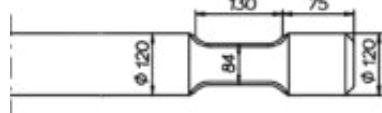
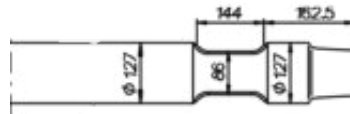
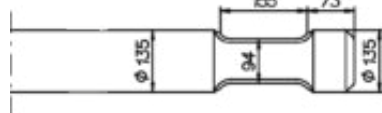
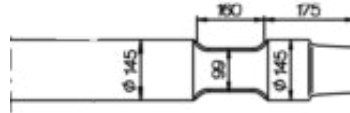
							solida - Nr.
Komac KB 350							
Spitzmeissel		-	820	26		70 682 01 082	
Flachmeissel (quer)		75	820	26		70 682 02 082	
Breitmeissel (quer)		150	750	25		70 682 34 075	
Asphaltspaten (parallel)		150	780	25		70 682 65 078	
Stampfwerkzeug		200 x 200	770	35		70 682 95 077	
Komac KB 400							
Spitzmeissel		-	800	31		70 683 01 080	
Flachmeissel (quer)		85	800	31		70 683 02 080	
Breitmeissel (quer)		180	740	30		70 683 22 074	
Asphaltspaten (parallel)		200	780	31		70 683 55 078	
Komac KB 1000							
Spitzmeissel		-	1000	52		70 684 01 100	
Flachmeissel (quer)		100	1000	52		70 684 02 100	
Breitmeissel (quer)		200	950	52		70 684 24 095	
Stampfmeissel		-	930	52		70 684 00 093	
Komac KB 1500							
Spitzmeissel		-	1000	79		70 737 01 100	
Flachmeissel (quer)		120	1000	79		70 737 02 100	
Stampfmeissel		-	920	79		70 737 00 092	
Komac TOR 22 / TOR 23							
Spitzmeissel		-	1150	98		70 690 01 115	
Flachmeissel (quer)		130	1150	98		70 690 02 115	
Stampfmeissel		-	1070	98		70 690 00 107	
Komac KB 2000							
Spitzmeissel		-	1200	118		70 738 01 120	
Flachmeissel (quer)		135	1200	118		70 738 02 120	
Stampfmeissel		-	1100	118		70 738 00 110	
Komac TOR 36							
Spitzmeissel		-	1300	145		70 691 01 130	
Flachmeissel (quer)		145	1300	145		70 691 02 130	
Stampfmeissel		-	1200	145		70 691 00 120	







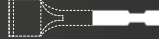

Komac KB 3600

Spitzmeissel		-	1300	157	70 740 01 130
Flachmeissel (quer)		150	1300	157	70 740 02 130
Stampfmeissel		-	1200	157	70 740 00 120

Komac KB 4200

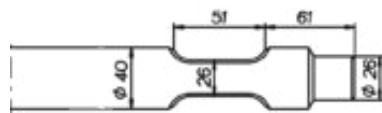
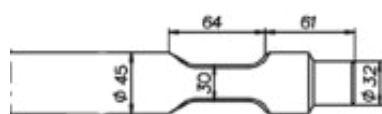
Spitzmeissel		-	1450	189	70 692 01 145
Flachmeissel (quer)		155	1450	189	70 692 02 145
Stampfmeissel		-	1350	189	70 692 00 135

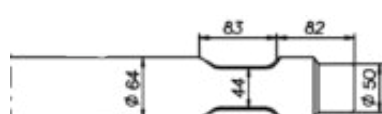
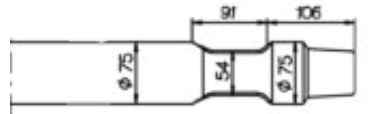
						solida - Nr.
Komatsu JTHB 08						
Spitzmeissel		–	450	4		70 142 01 045
Flachmeissel (quer)		42	450	4		70 142 02 045
Breitmeissel (quer)		120	410	4		70 142 70 041
Asphaltspaten (parallel)		100	420	4		70 142 43 042
Stampfwerkzeug		200 x 200	450	16		70 142 95 045
Komatsu JTHB 10						
Spitzmeissel		–	480	5		70 143 01 048
Flachmeissel (quer)		45	480	5		70 143 02 048
Breitmeissel (quer)		120	440	5		70 143 70 044
Asphaltspaten (parallel)		100	450	5		70 143 43 045
Stampfwerkzeug		200 x 200	450	17		70 143 95 045
Komatsu JTHB 20						
Spitzmeissel		–	510	7		70 701 01 051
Flachmeissel (quer)		50	510	7		70 701 02 051
Breitmeissel (quer)		140	480	7		70 701 18 048
Asphaltspaten (parallel)		115	490	7		70 701 83 049
Stampfwerkzeug		200 x 200	480	19		70 701 95 048
Komatsu JTHB 40						
Spitzmeissel		–	700	16		70 140 01 070
Flachmeissel (quer)		65	700	16		70 140 02 070
Breitmeissel (quer)		150	650	16		70 140 34 065
Asphaltspaten (parallel)		130	670	16		70 140 69 067
Stampfwerkzeug		200 x 200	650	26		70 140 95 065
Komatsu JTHB 50						
Spitzmeissel		–	720	22		70 704 01 072
Spitzmeissel		–	900	29		70 704 01 090
Flachmeissel (quer)		75	720	22		70 704 02 072
Breitmeissel (quer)		150	670	22		70 704 34 067
Asphaltspaten (parallel)		150	700	22		70 704 65 070
Stampfwerkzeug		200 x 200	670	30		70 704 95 067



Komatsu JTHB 60 / 65

Spitzmeissel		-	840	40	70 703 01 084
Spitzmeissel		-	1000	49	70 703 01 100
Flachmeissel (quer)		95	840	40	70 703 02 084
Breitmeissel (quer)		200	800	40	70 703 24 080
Asphaltspaten (parallel)		200	830	40	70 703 55 083

Komatsu JTHB 70

Spitzmeissel		-	940	65	70 705 01 094
Spitzmeissel		-	1060	75	70 705 01 106
Flachmeissel (quer)		115	940	65	70 705 02 094
Stampfmeissel		-	860	65	70 705 00 086

Komatsu JTHB 100

Spitzmeissel		-	1050	74	70 144 01 105
Flachmeissel (quer)		115	1050	74	70 144 02 105
Stampfmeissel		-	980	74	70 144 00 098

Komatsu JTHB 190





Spitzmeissel		-	1200	123	70 145 01 120
Flachmeissel (quer)		140	1200	123	70 145 02 120
Stampfmeissel		-	1100	123	70 145 00 110



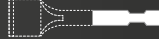

Komatsu JTHB 230



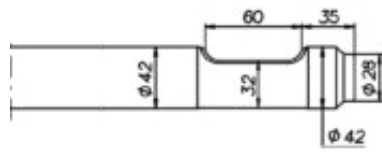
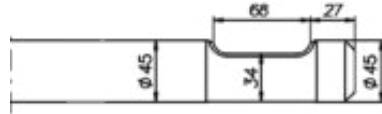
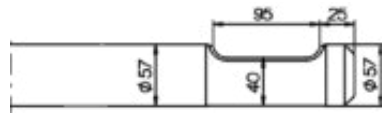
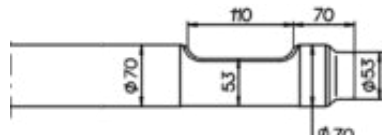
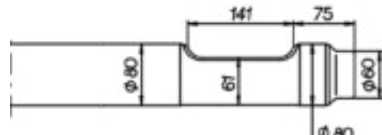
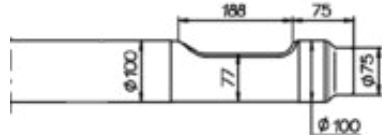



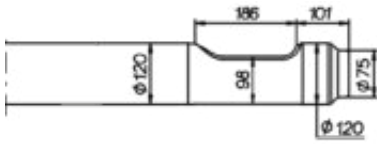
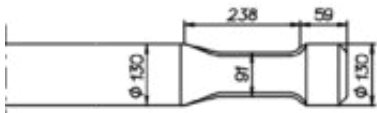
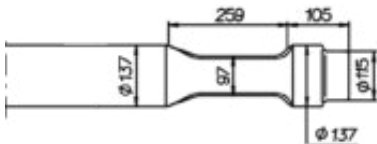
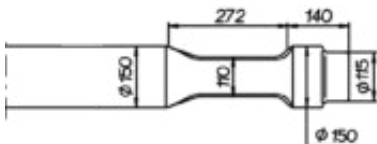

Spitzmeissel		-	1300	145	70 141 01 130
Flachmeissel (quer)		145	1300	145	70 141 02 130
Stampfmeissel		-	1200	145	70 141 00 120

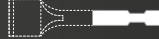
Komatsu utility PC 09-1 / PC 03-2 (FAI)

Spitzmeissel		-	600	5	70 910 01 060
Flachmeissel (quer)		42	600	5	70 910 02 060
Breitmeissel (quer)		120	550	5	70 910 70 055
Asphaltspaten (parallel)		100	580	5	70 910 43 058

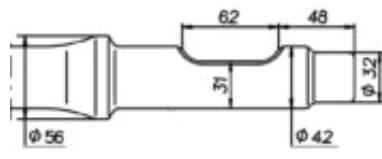
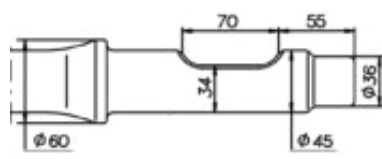
						solida - Nr.
Komatsu JKHB 51						
Spitzmeissel		-	410	4		70 829 01 041
Flachmeissel (quer)		42	410	4		70 829 02 041
Breitmeissel (quer)		120	440	5		70 829 70 044
Asphaltspaten (parallel)		100	450	5		70 829 43 045
Stampfwerkzeug		200 x 200	380	15		70 829 95 038
Komatsu JKHB 71						
Spitzmeissel		-	480	6		70 820 01 048
Flachmeissel (quer)		45	480	6		70 820 02 048
Breitmeissel (quer)		120	440	6		70 820 70 044
Asphaltspaten (parallel)		100	450	6		70 820 43 045
Stampfwerkzeug		200 x 200	450	17		70 820 95 045
Komatsu JKHB 101						
Spitzmeissel		-	580	10		70 826 01 058
Flachmeissel (quer)		57	580	10		70 826 02 058
Breitmeissel (quer)		140	550	10		70 826 18 055
Asphaltspaten (parallel)		115	560	10		70 826 83 056
Stampfwerkzeug		200 x 200	550	21		70 826 95 055
Komatsu JKHB 301						
Spitzmeissel		-	740	19		70 825 01 074
Flachmeissel (quer)		70	740	19		70 825 02 074
Breitmeissel (quer)		150	690	19		70 825 34 069
Asphaltspaten (parallel)		150	720	19		70 825 65 072
Stampfwerkzeug		200 x 200	690	29		70 825 95 069
Komatsu JKHB 401						
Spitzmeissel		-	900	32		70 822 01 090
Flachmeissel (quer)		80	900	32		70 822 02 090
Breitmeissel (quer)		180	860	32		70 822 22 086
Asphaltspaten (parallel)		180	890	32		70 822 53 089
Komatsu JKHB 801						
Spitzmeissel		-	1000	53		70 824 01 100
Flachmeissel (quer)		100	1000	53		70 824 02 100
Breitmeissel (quer)		200	950	53		70 824 24 095
Stampfmeissel		-	930	53		70 824 00 093

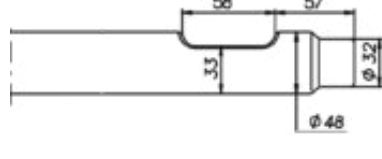
				solida - Nr.	
Komatsu JKHB 1101					
Spitzmeissel		-	1150	95	70 830 01 115
Flachmeissel (quer)		120	1150	95	70 830 02 115
Stampfmeissel		-	1070	95	70 830 00 107
Komatsu JKHB 1401					
Spitzmeissel		-	1100	100	70 833 01 110
Flachmeissel (quer)		130	1100	100	70 833 02 110
Stampfmeissel		-	1020	100	70 833 00 102
Komatsu JKHB 1500					
Spitzmeissel		-	1250	127	70 831 01 125
Flachmeissel (quer)		140	1250	127	70 831 02 125
Stampfmeissel		-	1170	127	70 831 00 117
Komatsu JKHB 2000					
Spitzmeissel		-	1350	162	70 827 01 135
Flachmeissel (quer)		150	1350	162	70 827 02 135
Stampfmeissel		-	1250	162	70 827 00 125

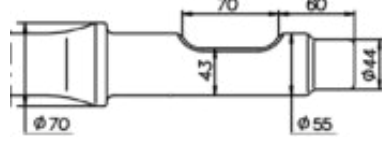
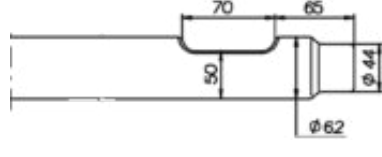
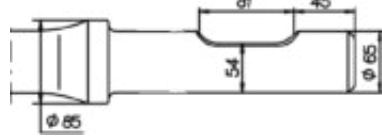
						solida - Nr.
Krupp HM 45						
Spitzmeissel		–	470	5		70 020 01 047
Flachmeissel (quer)		42	470	5		70 020 02 047
Breitmeissel (quer)		120	430	5		70 020 70 043
Asphaltspaten (parallel)		100	440	5		70 020 43 044
Stampfwerkzeug		200 x 200	440	17		70 020 95 044
Krupp HM 55 / 50 / 51 / 53						
Spitzmeissel		–	560	7		70 013 01 056
Flachmeissel (quer)		45	560	7		70 013 02 056
Breitmeissel (quer)		120	520	7		70 013 70 052
Asphaltspaten (parallel)		100	530	7		70 013 43 053
Stampfwerkzeug		200 x 200	530	18		70 013 95 053
Krupp HM 60 (ab Baujahr 1997) / HM 60 V 						
Spitzmeissel		–	510	7		70 023 01 051
Flachmeissel (quer)		50	510	7		70 023 02 051
Breitmeissel (quer)		140	480	7		70 023 18 048
Asphaltspaten (parallel)		115	490	7		70 023 83 049
Stampfwerkzeug		200 x 200	480	18		70 023 95 048
Krupp HM 60 (vor 1997) / 61 / 62 / 65 / 75 						
Spitzmeissel		–	590	10		70 009 01 059
Flachmeissel (quer)		55	590	10		70 009 02 059
Breitmeissel (quer)		140	560	10		70 009 18 056
Asphaltspaten (parallel)		115	570	10		70 009 83 057
Stampfwerkzeug		200 x 200	580	20		70 009 95 058
Krupp HM 85 / 90 V						
Spitzmeissel		–	600	13		70 021 01 060
Flachmeissel (quer)		62	600	13		70 021 02 060
Breitmeissel (quer)		150	550	13		70 021 34 055
Asphaltspaten (parallel)		130	570	13		70 021 69 057
Stampfwerkzeug		200 x 200	550	23		70 021 95 055
Krupp HM 100 / 110						
Spitzmeissel		–	700	17		70 001 01 070
Flachmeissel (quer)		65	700	17		70 001 02 070
Breitmeissel (quer)		180	670	17		70 001 22 067



Krupp HM 130 / 131 / 135 / 140 V

Spitzmeissel		-	800	19	70 015 01 080
Flachmeissel (quer)		65	800	19	70 015 02 080
Breitmeissel (quer)		150	750	19	70 015 34 075
Asphaltspaten (parallel)		130	770	19	70 015 69 077
Stampfwerkzeug		200 x 200	750	29	70 015 95 075

Krupp HM 170 / 185 / 190 V

Spitzmeissel		-	820	26	70 016 01 082
Flachmeissel (quer)		75	820	26	70 016 02 082
Breitmeissel (quer)		150	770	26	70 016 34 077
Asphaltspaten (parallel)		150	800	26	70 016 65 080
Stampfwerkzeug		200 x 200	770	35	70 016 95 077

Krupp HM 200

Spitzmeissel		-	910	33	70 002 01 091
Flachmeissel (quer)		80	910	33	70 002 02 091
Breitmeissel (quer)		200	880	33	70 002 24 088

Krupp HM 220 / 230

Spitzmeissel		-	800	29	70 029 01 080
Flachmeissel (quer)		80	800	29	70 029 02 080
Breitmeissel (quer)		160	760	29	70 029 20 076
Asphaltspaten (parallel)		150	790	29	70 029 65 079

Krupp HM 300 / 301 / 303 / 305







Spitzmeissel		-	900	31	70 010 01 090
Flachmeissel (quer)		80	900	31	70 010 02 090
Breitmeissel (quer)		180	860	31	70 010 22 086
Asphaltspaten (parallel)		180	890	31	70 010 53 089



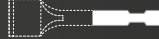

Krupp HM 400 / 401 / 405

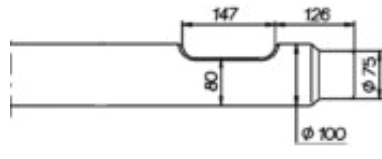
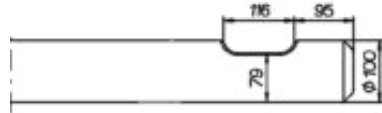
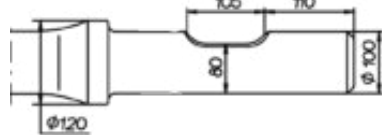
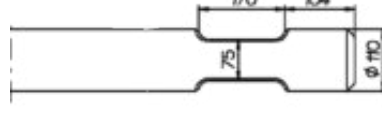
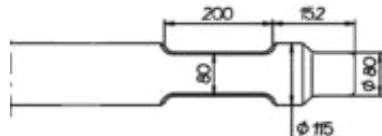

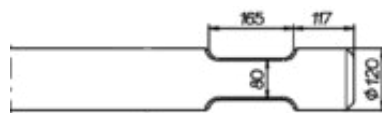



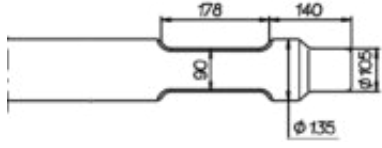
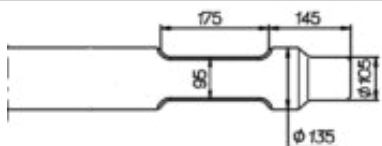
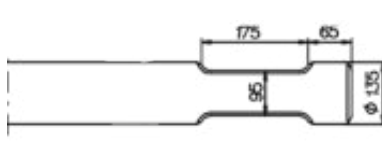
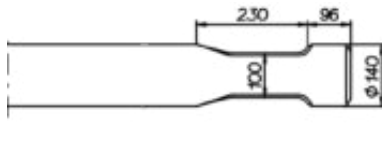
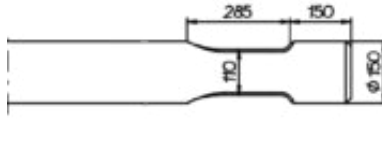
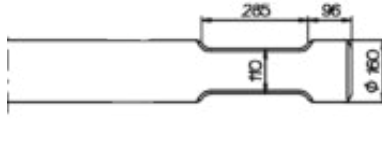
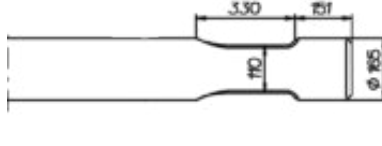
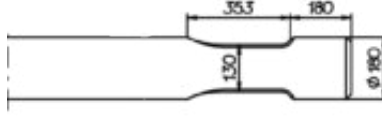

Spitzmeissel		-	800	29	70 003 01 080
Flachmeissel (quer)		80	800	29	70 003 02 080
Breitmeissel (quer)		160	760	29	70 003 20 076

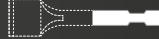



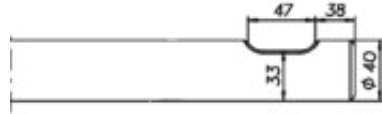

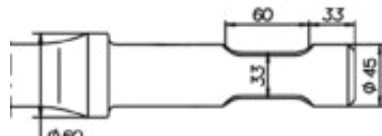
Krupp HM 350 V

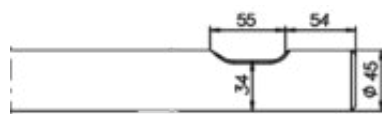





Spitzmeissel		-	900	39	70 024 01 090
Flachmeissel (quer)		90	900	39	70 024 02 090
Breitmeissel (quer)		180	840	39	70 024 22 084
Asphaltspaten (parallel)		200	880	39	70 024 55 088

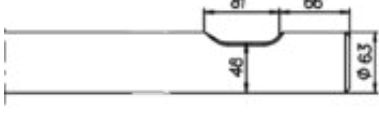
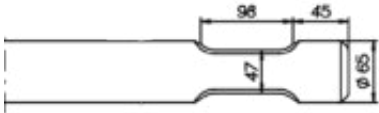
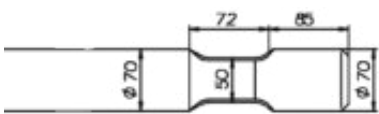

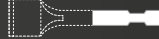



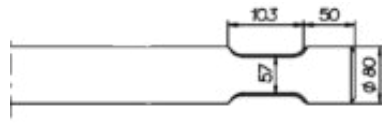





						_solida - Nr.
Krupp HM 550 / 551 / 553 / 555 / 560 / 560 CS / 560 V						
Spitzmeissel		-	1000	53	70 012 01 100	
Flachmeissel (quer)		100	1000	53	70 012 02 100	
Breitmeissel (quer)		200	950	53	70 012 24 095	
Stampfmeissel		-	930	53	70 012 00 093	
Krupp HM 580						
Spitzmeissel		-	1000	56	70 027 01 100	
Flachmeissel (quer)		100	1000	56	70 027 02 100	
Breitmeissel (quer)		200	950	56	70 027 24 095	
Stampfmeissel		-	930	56	70 027 00 093	
Krupp HM 600 / 601						
Spitzmeissel		-	1000	57	70 004 01 100	
Flachmeissel (quer)		100	1000	57	70 004 02 100	
Breitmeissel (quer)		240	940	57	70 004 26 094	
Stampfmeissel		-	920	57	70 004 00 092	
Krupp HM 680						
Spitzmeissel		-	1100	79	70 034 01 110	
Flachmeissel (quer)		120	1100	79	70 034 02 110	
Breitmeissel (quer)		240	1040	79	70 034 26 104	
Stampfmeissel		-	1020	79	70 034 00 102	
Krupp HM 700 / 701 / 702 / 703 / 705 / 706						
Spitzmeissel		-	1100	78	70 007 01 110	
Flachmeissel (quer)		115	1100	78	70 007 02 110	
Stampfmeissel		-	1020	78	70 007 00 102	
Krupp HM 720 CS / HM 710 / 711 / 712 / 713 / 715 / 720 / 720 V						
Spitzmeissel		-	1060	76	70 017 01 106	
Flachmeissel (quer)		115	1060	76	70 017 02 106	
Breitmeissel (quer)		240	1000	76	70 017 26 100	
Stampfmeissel		-	980	76	70 017 00 098	
Krupp HM 780 / Marathon						
Spitzmeissel		-	1100	87	70 028 01 110	
Flachmeissel (quer)		120	1100	87	70 028 02 110	
Stampfmeissel		-	1020	87	70 028 00 102	



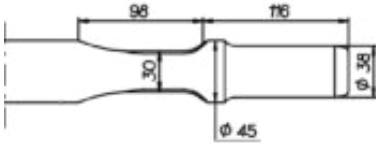

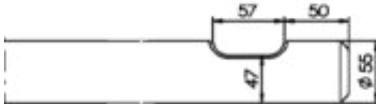
						solida - Nr.
Krupp HM 800						
Spitzmeissel		-	1100	114	70 005 01 120	
Flachmeissel (quer)		135	1100	114	70 005 02 120	
Stampfmeissel		-	1020	114	70 005 00 110	
Krupp HM 900 / 901 / 902 / 904						
Spitzmeissel		-	1100	114	70 006 01 120	
Flachmeissel (quer)		135	1100	114	70 006 02 120	
Stampfmeissel		-	1020	114	70 006 00 110	
Krupp HM 950 / 951 / 952 / 954 / 957 / 960 CS / 960 V						
Spitzmeissel		-	1100	107	70 018 01 110	
Sprengmeissel		-	1200	107	70 018 90 120	
Flachmeissel (quer)		135	1100	107	70 018 02 110	
Stampfmeissel		-	1000	107	70 018 00 100	
Krupp HM 1000 / Marathon						
Spitzmeissel		-	1200	128	70 026 01 120	
Flachmeissel (quer)		140	1200	128	70 026 02 120	
Stampfmeissel		-	1100	128	70 026 00 110	
Krupp HM 1300 / 1500 / 1500 CS / 1500 V / Marathon						
Spitzmeissel		-	1300	160	70 030 01 130	
Flachmeissel (quer)		150	1300	160	70 030 02 130	
Stampfmeissel		-	1200	160	70 030 00 120	
Krupp HM 1800 / 2000 / V / Marathon						
Spitzmeissel		-	1300	178	70 014 01 130	
Flachmeissel (quer)		160	1300	178	70 014 02 130	
Stampfmeissel		-	1200	178	70 014 00 120	
Krupp HM 2100 / 2300 / V / Marathon						
Spitzmeissel		-	1350	197	70 032 01 135	
Flachmeissel (quer)		165	1350	197	70 032 02 135	
Stampfmeissel		-	1250	197	70 032 00 125	
Krupp HM 2200 / 2500 / 2600 / V / Marathon						
Spitzmeissel		-	1700	308	70 033 01 170	
Flachmeissel (quer)		180	1700	308	70 033 02 170	
Stampfmeissel		-	1600	308	70 033 00 160	

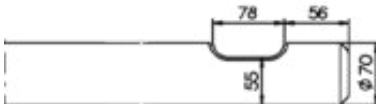
							
Kubota KM 55							
Spitzmeißel		–	420	5	70 500 01 042		
Flachmeißel (quer)		42	420	5	70 500 02 042		
Breitmeißel (quer)		120	370	5	70 500 70 037		
Asphaltspaten (parallel)		100	400	5	70 500 43 040		
Stampfwerkzeug		200 x 200	400	16	70 500 95 040		
Kubota KXB 300 N / KXB 350 N							
Spitzmeißel		–	410	4	70 573 01 041		
Flachmeißel (quer)		42	410	4	70 573 02 041		
Breitmeißel (quer)		120	370	4	70 573 70 037		
Asphaltspaten (parallel)		100	380	4	70 573 43 038		
Stampfwerkzeug		200 x 200	380	16	70 573 95 038		
Kubota KM 100							
Spitzmeißel		–	550	7	70 503 01 055		
Spitzmeißel		–	700	8	70 503 01 070		
Flachmeißel (quer)		45	550	7	70 503 02 055		
Breitmeißel (quer)		120	510	7	70 503 70 051		
Asphaltspaten (parallel)		125	480	7	70 503 47 048		
Stampfwerkzeug		200 x 200	520	18	70 503 95 052		
Kubota KM 105							
Spitzmeißel		–	450	5	70 502 01 045		
Spitzmeißel		–	580	7	70 502 01 058		
Flachmeißel (quer)		45	450	5	70 502 02 045		
Breitmeißel (quer)		120	410	5	70 502 70 041		
Asphaltspaten (parallel)		100	420	5	70 502 43 042		
Stampfwerkzeug		200 x 200	430	17	70 502 95 043		
Kubota KXB 400 N							
Spitzmeißel		–	480	6	70 566 01 048		
Spitzmeißel		–	580	7	70 566 01 058		
Flachmeißel (quer)		45	480	6	70 566 02 048		
Breitmeißel (quer)		120	440	6	70 566 70 044		
Asphaltspaten (parallel)		100	450	6	70 566 43 045		
Stampfwerkzeug		200 x 200	450	17	70 566 95 045		

						kg	solida - Nr.
Kubota KM 150 / 155							
Spitzmeissel		-	510	7	70 510 01 051		
Spitzmeissel		-	750	11	70 510 01 075		
Flachmeissel (quer)		50	510	7	70 510 02 051		
Breitmeissel (quer)		125	480	7	70 510 16 048		
Asphaltspaten (parallel)		115	490	7	70 510 83 049		
Stampfwerkzeug		200 x 200	470	18	70 510 95 047		
Kubota KXB 450 N							
Spitzmeissel		-	510	8	70 576 01 051		
Spitzmeissel		-	750	11	70 576 01 075		
Flachmeissel (quer)		50	510	8	70 576 02 051		
Breitmeissel (quer)		140	480	7	70 576 18 048		
Asphaltspaten (parallel)		115	490	7	70 576 83 049		
Stampfwerkzeug		200 x 200	480	19	70 576 95 048		
Kubota KXB 500 N							
Spitzmeissel		-	700	16	70 565 01 070		
Spitzmeissel		-	810	19	70 565 01 081		
Flachmeissel (quer)		65	700	16	70 565 02 070		
Breitmeissel (quer)		150	550	13	70 565 34 055		
Asphaltspaten (parallel)		130	570	13	70 565 69 057		
Stampfwerkzeug		200 x 200	650	26	70 565 95 065		
Kubota KM 200 / 205							
Spitzmeissel		-	600	13	70 509 01 060		
Spitzmeissel		-	800	19	70 509 01 080		
Flachmeissel (quer)		65	600	13	70 509 02 060		
Breitmeissel (quer)		125	650	16	70 509 16 065		
Asphaltspaten (parallel)		130	670	16	70 509 69 067		
Stampfwerkzeug		200 x 200	550	24	70 509 95 055		
Kubota KXB 600 N							
Spitzmeissel		-	740	20	70 567 01 074		
Flachmeissel (quer)		70	740	20	70 567 02 074		
Breitmeissel (quer)		150	690	20	70 567 34 069		
Asphaltspaten (parallel)		150	720	20	70 567 65 072		
Stampfwerkzeug		200 x 200	690	30	70 567 95 069		

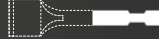
										_solida - Nr.	
Kubota KM 300 / 305											
Spitzmeissel		–	800	28	70 514 01 080						
Flachmeissel (quer)		80	800	28	70 514 02 080						
Breitmeissel (quer)		160	770	28	70 514 20 077						
Asphaltspaten (parallel)		180	790	28	70 514 53 079						
Kubota KM 450 / 455											
Spitzmeissel		–	840	41	70 511 01 084						
Flachmeissel (quer)		95	840	41	70 511 02 084						
Breitmeissel (quer)		180	800	41	70 511 22 080						
Asphaltspaten (parallel)		200	830	41	70 511 55 083						

							kg	solida - Nr.
Lifton LH 60								
Spitzmeissel		–	500	6	70 055 01 050			
Flachmeissel (quer)		45	500	6	70 055 02 050			
Breitmeissel (quer)		120	460	6	70 055 70 046			
Asphaltspaten (parallel)		100	470	6	70 055 43 047			
Stempfwerkzeug		200 x 200	470	17	70 055 95 047			
Lifton LH 70 / 80								
Spitzmeissel		–	500	6	70 460 01 050			
Flachmeissel (quer)		45	500	6	70 460 02 050			
Breitmeissel (quer)		120	470	6	70 460 70 047			
Asphaltspaten (parallel)		100	470	6	70 460 43 047			
Stempfwerkzeug		200 x 200	470	18	70 460 95 047			
Lifton LH 100 / 110								
Spitzmeissel		–	530	9	70 461 01 053			
Flachmeissel (quer)		55	530	9	70 461 02 053			
Breitmeissel (quer)		140	500	9	70 461 18 050			
Asphaltspaten (parallel)		115	510	9	70 461 83 051			
Stempfwerkzeug		200 x 200	500	20	70 461 95 050			
Lifton LH 200								
Spitzmeissel		–	600	13	70 467 01 060			
Flachmeissel (quer)		65	600	13	70 467 02 060			
Breitmeissel (quer)		150	550	13	70 467 34 055			
Asphaltspaten (parallel)		130	570	13	70 467 69 057			
Stempfwerkzeug		200 x 200	550	24	70 467 95 055			
Lifton LH 300 / 170								
Spitzmeissel		–	740	20	70 462 01 074			
Flachmeissel (quer)		70	740	20	70 462 02 074			
Breitmeissel (quer)		150	690	20	70 462 34 069			
Asphaltspaten (parallel)		150	720	20	70 462 65 072			
Lifton LH 360								
Spitzmeissel		–	780	29	70 463 01 078			
Flachmeissel (quer)		82	780	29	70 463 02 078			
Breitmeissel (quer)		180	740	29	70 463 22 074			
Asphaltspaten (parallel)		180	770	29	70 463 53 077			

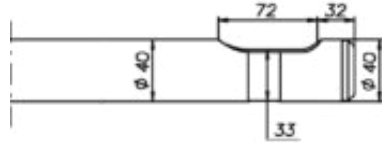
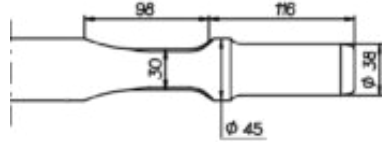
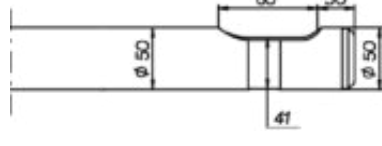
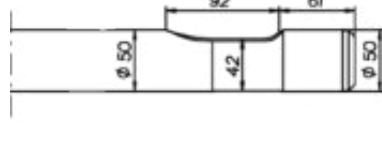
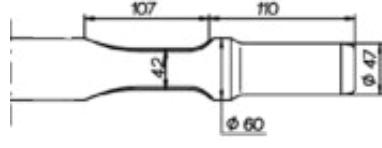
							solida - Nr.
Montabert BRP 30 / M 30							
Spitzmeißel		-	410	4			70 068 01 041
Spitzmeißel		-	560	6			70 068 01 056
Flachmeißel (quer)		42	410	4			70 068 02 041
Breitmeißel (quer)		120	440	5			70 068 70 044
Asphaltspaten (parallel)		100	450	5			70 068 43 045
Stampfwerkzeug		200 x 200	380	15			70 068 95 038
Montabert BRH 40							
Spitzmeißel		-	500	6			70 055 01 050
Spitzmeißel		-	700	8			70 055 01 070
Flachmeißel (quer)		45	500	6			70 055 02 050
Breitmeißel (quer)		120	460	6			70 055 70 046
Asphaltspaten (parallel)		100	470	6			70 055 43 047
Stampfwerkzeug		200 x 200	470	17			70 055 95 047
Montabert BRP 45 / 50 / M 50							
Spitzmeißel		-	430	6			70 065 01 043
Spitzmeißel		-	750	11			70 065 01 075
Flachmeißel (quer)		50	430	6			70 065 02 043
Breitmeißel (quer)		140	400	6			70 065 18 040
Asphaltspaten (parallel)		115	410	6			70 065 83 041
Stampfwerkzeug		200 x 200	400	17			70 065 95 040
Montabert BRP 70 / 60 / M 60 / M 70							
Spitzmeißel		-	510	8			70 064 01 051
Spitzmeißel		-	750	11			70 064 01 075
Flachmeißel (quer)		50	510	8			70 064 02 051
Breitmeißel (quer)		140	480	8			70 064 18 048
Asphaltspaten (parallel)		115	490	8			70 064 83 049
Stampfwerkzeug		200 x 200	480	18			70 064 95 048
Montabert BRH 75 / 76 / 90 / 91							
Spitzmeißel		-	540	10			70 060 01 054
Flachmeißel (quer)		60	540	10			70 060 02 054
Breitmeißel (quer)		150	500	10			70 060 34 050
Asphaltspaten (parallel)		130	520	10			70 060 69 052
Stampfwerkzeug		200 x 200	500	21			70 060 95 050



Montabert BRP 85 / 95 / 100 / M 85 / M 95

Spitzmeissel		-	600	13	70 070 01 060
Spitzmeissel		-	900	21	70 070 01 090
Flachmeissel (quer)		62	600	13	70 070 02 060
Breitmeissel (quer)		150	550	13	70 070 34 055
Asphaltspaten (parallel)		130	570	13	70 070 69 057
Stampfwerkzeug		200 x 200	550	23	70 070 95 055

Montabert M 125 SX

Spitzmeissel		-	720	22	70 075 01 072
Flachmeissel (quer)		75	720	22	70 075 02 072
Breitmeissel (quer)		150	670	22	70 075 34 067
Asphaltspaten (parallel)		150	700	22	70 075 65 070
Stampfwerkzeug		200 x 200	670	31	70 075 95 067

Montabert BRP 130 / 140 / 150 / M 130 / M 140 / M 150





Spitzmeissel		-	720	22	70 069 01 072
Flachmeissel (quer)		75	720	22	70 069 02 072
Breitmeissel (quer)		150	670	22	70 069 34 067
Asphaltspaten (parallel)		150	700	22	70 069 65 070
Stampfwerkzeug		200 x 200	670	31	70 069 95 067



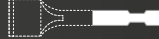

Montabert BRH 125



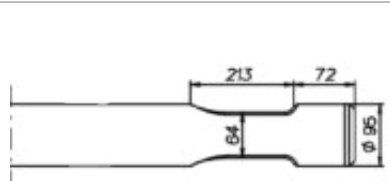
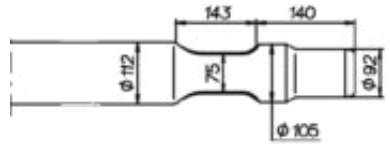
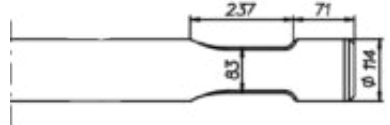
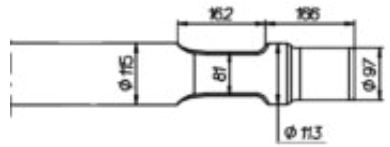
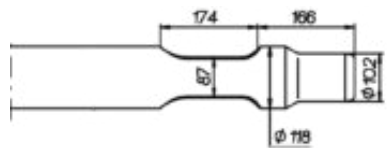
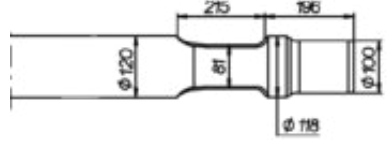
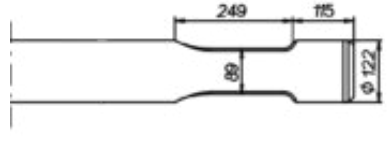

Spitzmeissel		-	700	22	70 051 01 070
Spitzmeissel		-	920	31	70 051 01 092
Flachmeissel (quer)		80	700	22	70 051 02 070
Flachmeissel (quer)		80	920	31	70 051 02 092
Breitmeissel (quer)		180	660	22	70 051 22 066
Asphaltspaten (parallel)		180	690	22	70 051 53 069

Montabert M 300

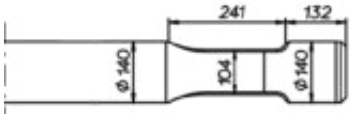
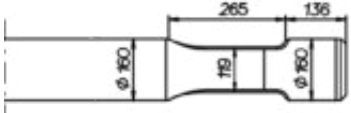
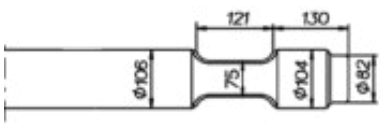
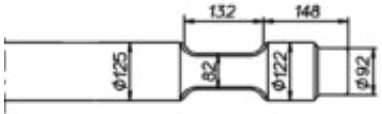
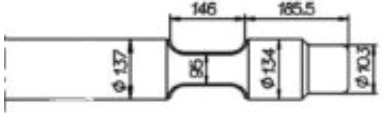
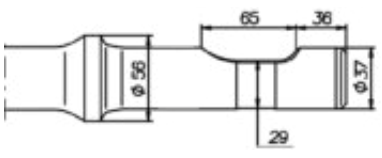
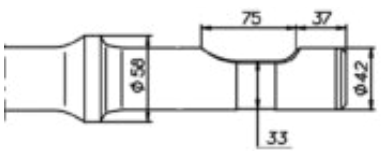
Spitzmeissel		-	850	41	70 074 01 085
Flachmeissel (quer)		95	850	41	70 074 02 085
Breitmeissel (quer)		200	800	41	70 074 24 080
Asphaltspaten (parallel)		200	830	41	70 074 55 083

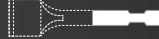
							solida - Nr.
Montabert BRH 250 / 270							
Spitzmeissel		–	840	40	–	70 052 01 084	
Spitzmeissel		–	1200	60	–	70 052 01 120	
Flachmeissel (quer)		95	840	40	–	70 052 02 084	
Breitmeissel (quer)		200	800	40	–	70 052 24 080	
Asphaltspaten (parallel)		200	830	40	–	70 052 55 083	
Montabert M 700							
Spitzmeissel		–	940	63	–	70 072 01 094	
Flachmeissel (quer)		114	940	63	–	70 072 02 094	
Breitmeissel (quer)		240	880	63	–	70 072 26 088	
Montabert BRH 501 / 570							
Spitzmeissel		–	1000	70	–	70 053 01 100	
Spitzmeissel		–	1300	95	–	70 053 01 130	
Flachmeissel (quer)		114	1000	70	–	70 053 02 100	
Breitmeissel (quer)		240	940	70	–	70 053 26 094	
Stampfmeissel		–	920	70	–	70 053 00 092	
Montabert BRH 620							
Spitzmeissel		–	1060	73	–	70 059 01 106	
Flachmeissel (quer)		115	1060	73	–	70 059 02 106	
Stampfmeissel		–	980	73	–	70 059 00 098	
Montabert BRH 625 / M 900							
Spitzmeissel		–	1000	73	–	70 062 01 100	
Spitzmeissel		–	1300	101	–	70 062 01 130	
Flachmeissel (quer)		118	1000	73	–	70 062 02 100	
Stampfmeissel		–	920	73	–	70 062 00 092	
Montabert BRH 750							
Spitzmeissel		–	1100	81	–	70 058 01 110	
Flachmeissel (quer)		120	1100	81	–	70 058 02 110	
Stampfmeissel		–	1020	81	–	70 058 00 102	
Montabert BRV 32 / V 32 / V 1200							
Spitzmeissel		–	1100	89	–	70 061 01 110	
Spitzmeissel		–	1300	106	–	70 061 01 130	
Flachmeissel (quer)		122	1100	89	–	70 061 02 110	
Stampfmeissel		–	1020	89	–	70 061 00 102	



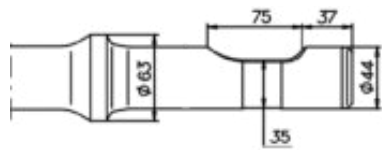
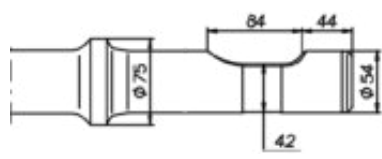
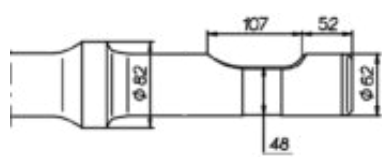
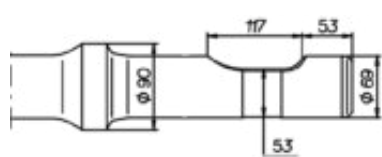
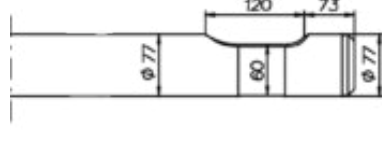
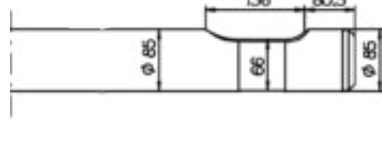

							solida - Nr.
Montabert V 1800							
Spitzmeissel		-	1270	136	70 084 01 127		
Flachmeissel (quer)		140	1270	136	70 084 02 127		
Stampfmeissel		-	1170	136	70 084 00 117		
Montabert V 2500							
Spitzmeissel		-	1500	220	70 085 01 150		
Flachmeissel (quer)		160	1500	220	70 085 02 150		
Stampfmeissel		-	1400	220	70 085 00 140		
Montabert XL 1000							
Spitzmeissel		-	1000	65	70 086 01 100		
Flachmeissel (quer)		114	1000	65	70 086 02 100		
Breitmeissel (quer)		240	940	65	70 086 26 094		
Stampfmeissel		-	920	65	70 086 00 092		
Montabert XL 1300							
Spitzmeissel		-	1100	92	70 088 01 110		
Flachmeissel (quer)		125	1100	92	70 088 02 110		
Stampfmeissel		-	1020	92	70 088 00 102		
Montabert XL 1700							
Spitzmeissel		-	1200	119	70 087 01 120		
Flachmeissel (quer)		140	1200	119	70 087 02 120		
Stampfmeissel		-	1100	119	70 087 00 110		
Montabert SC 6							
Spitzmeissel		-	440	4	70 082 01 044		
Flachmeissel (quer)		40	440	4	70 082 02 044		
Breitmeissel (quer)		120	410	5	70 082 70 041		
Asphaltspaten (parallel)		100	430	5	70 082 43 043		
Montabert SC 8							
Spitzmeissel		-	440	5	70 080 01 044		
Flachmeissel (quer)		42	440	5	70 080 02 044		
Breitmeissel (quer)		120	390	5	70 080 70 039		
Asphaltspaten (parallel)		100	400	5	70 080 43 040		
Stampfwerkzeug		200 x 200	410	16	70 080 95 041		



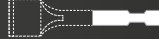

						solida - Nr.
Montabert SC 12						
Spitzmeissel		–	460	6		70 076 01 046
Flachmeissel (quer)		45	460	6		70 076 02 046
Breitmeissel (quer)		140	430	6		70 076 18 043
Asphaltspaten (parallel)		115	440	6		70 076 83 044
Stampfwerkzeug		200 x 200	430	17		70 076 95 043
Montabert SC 16						
Spitzmeissel		–	540	9		70 079 01 054
Flachmeissel (quer)		54	540	9		70 079 02 054
Breitmeissel (quer)		140	500	9		70 079 18 050
Asphaltspaten (parallel)		115	510	9		70 079 83 051
Stampfwerkzeug		200 x 200	510	21		70 079 95 051
Montabert SC 22						
Spitzmeissel		–	600	14		70 077 01 060
Flachmeissel (quer)		62	600	14		70 077 02 060
Breitmeissel (quer)		150	540	14		70 077 34 054
Asphaltspaten (parallel)		130	560	14		70 077 69 056
Stampfwerkzeug		200 x 200	550	24		70 077 95 055
Montabert SC 28						
Spitzmeissel		–	650	19		70 078 01 065
Flachmeissel (quer)		69	650	19		70 078 02 065
Breitmeissel (quer)		180	610	19		70 078 22 061
Asphaltspaten (parallel)		200	660	20		70 078 55 066
Stampfwerkzeug		200 x 200	600	28		70 078 95 060
Montabert SC 36						
Spitzmeissel		–	700	23		70 081 01 070
Flachmeissel (quer)		77	700	23		70 081 02 070
Breitmeissel (quer)		150	650	23		70 081 34 065
Asphaltspaten (parallel)		160	680	30		70 081 63 068
Montabert SC 42						
Spitzmeissel		–	790	31		70 083 01 079
Flachmeissel (quer)		85	790	31		70 083 02 079
Breitmeissel (quer)		180	740	31		70 083 22 074
Asphaltspaten (parallel)		180	770	31		70 083 53 077



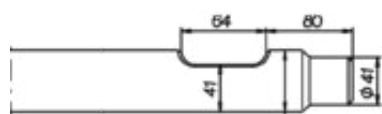
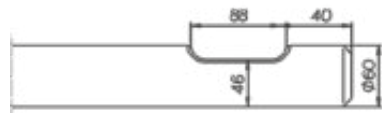
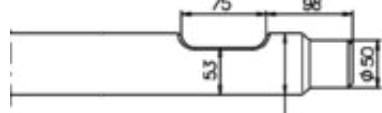
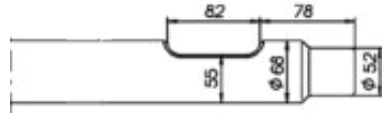
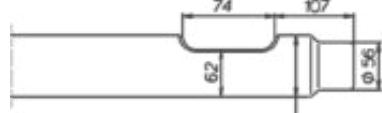





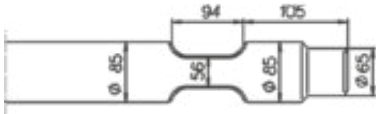
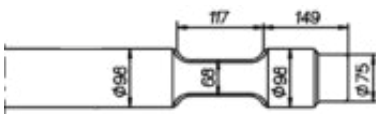
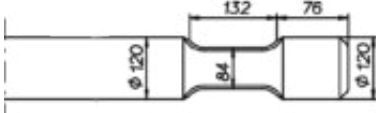
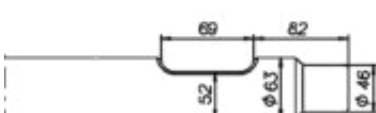
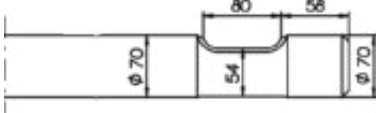
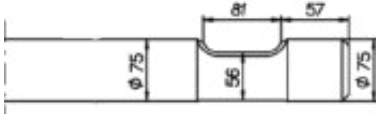

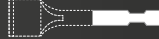

Montabert SC 50

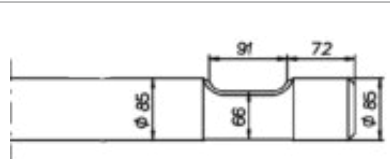
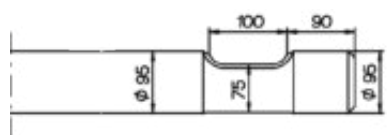
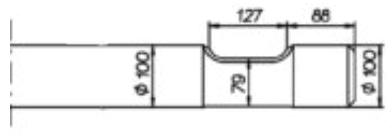
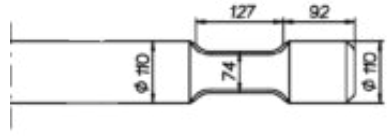
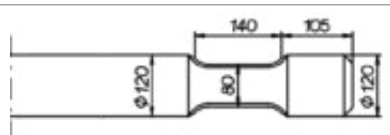
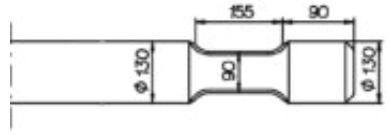



Spitzmeissel		-	850	41	70 074 01 085
Flachmeissel (quer)		95	850	41	70 074 02 085
Breitmeissel (quer)		200	800	41	70 074 24 080
Asphaltspaten (parallel)		200	830	41	70 074 55 083



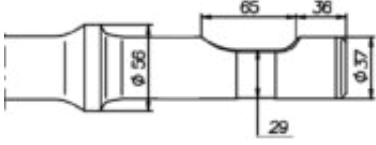
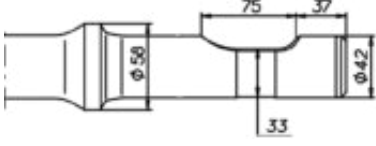
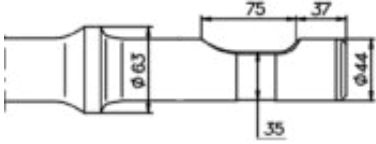
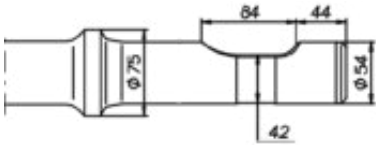
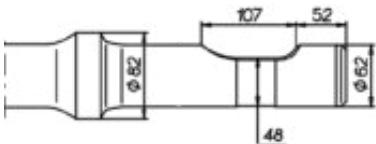
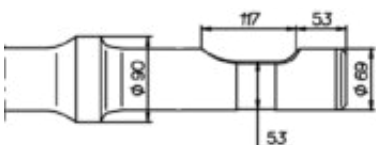

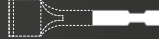
						solida - Nr.
MSB Saga 20 / 20 H / 20 II						
Spitzmeissel		–	480	4,5		70 439 01 048
Flachmeissel (quer)		45	480	4,5		70 439 02 048
Breitmeissel (quer)		120	440	4,5		70 439 70 044
Asphaltspaten (parallel)		100	450	4,5		70 439 43 045
Stampfwerkzeug		200 x 200	450	16		70 439 95 045
MSB Saga 30 / 30 H / 30 II						
Spitzmeissel		–	530	9		70 720 01 053
Flachmeissel (quer)		55	530	9		70 720 02 053
Breitmeissel (quer)		140	500	9		70 720 18 050
Asphaltspaten (parallel)		115	510	9		70 720 83 051
Stampfwerkzeug		200 x 200	500	20		70 720 95 050
MSB Saga 40 / 40 H / 40 II						
Spitzmeissel		–	590	12		70 372 01 059
Flachmeissel (quer)		62	590	12		70 372 02 059
Breitmeissel (quer)		150	550	12		70 372 34 055
Asphaltspaten (parallel)		130	570	12		70 372 69 057
Stampfwerkzeug		200 x 200	550	23		70 372 95 055
MSB Saga 50 / 50 H						
Spitzmeissel		–	740	19		70 722 01 074
Flachmeissel (quer)		68	740	19		70 722 02 074
Breitmeissel (quer)		150	690	19		70 722 34 069
Asphaltspaten (parallel)		150	720	19		70 722 65 072
Stampfwerkzeug		200 x 200	690	31		70 722 95 069
MSB Saga 2000						
Spitzmeissel		–	740	19		70 438 01 074
Flachmeissel (quer)		68	740	19		70 438 02 074
Breitmeissel (quer)		150	690	19		70 438 34 069
Asphaltspaten (parallel)		150	720	19		70 438 65 072
Stampfwerkzeug		200 x 200	690	31		70 438 95 069
MSB Saga 80 / 80 H						
Spitzmeissel		–	750	24		70 373 01 075
Flachmeissel (quer)		76	750	24		70 373 02 075
Breitmeissel (quer)		150	700	24		70 373 34 070
Asphaltspaten (parallel)		160	730	24		70 373 63 073



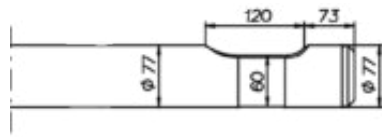
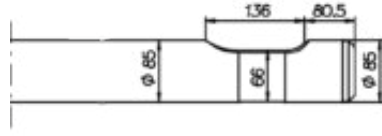
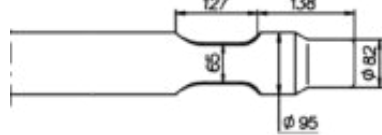

						solida - Nr.
MSB Saga 100 / 100 H						
Spitzmeissel		-	900	36	70 374 01 090	
Flachmeissel (quer)		85	900	36	70 374 02 090	
Breitmeissel (quer)		180	860	36	70 374 22 086	
Asphaltspaten (parallel)		180	890	36	70 374 53 089	
MSB Saga 120 / 120 H						
Spitzmeissel		-	1000	51	70 725 01 100	
Flachmeissel (quer)		100	1000	51	70 725 02 100	
Breitmeissel (quer)		200	950	51	70 725 24 095	
Stampfmeissel		-	930	51	70 725 00 093	
MSB Saga 180 / 180 H						
Spitzmeissel		-	1100	87	70 726 01 110	
Flachmeissel (quer)		120	1100	87	70 726 02 110	
Stampfmeissel		-	1020	87	70 726 00 102	
MSB MS 200 / 200 H						
Spitzmeissel		-	600	13	70 435 01 060	
Flachmeissel (quer)		65	600	13	70 435 02 060	
Breitmeissel (quer)		150	550	13	70 435 34 055	
Asphaltspaten (parallel)		130	570	13	70 435 69 057	
Stampfwerkzeug		200 x 200	550	24	70 435 95 055	
MSB MS 220 / 220 H						
Spitzmeissel		-	740	20	70 440 01 074	
Flachmeissel (quer)		70	740	20	70 440 02 074	
Breitmeissel (quer)		150	690	20	70 440 34 069	
Asphaltspaten (parallel)		150	720	20	70 440 65 072	
Stampfwerkzeug		200 x 200	690	31	70 440 95 069	
MSB MS 225 / 225 H / 250 / 250 H / 255 / 255 H						
Spitzmeissel		-	720	23	70 447 01 072	
Flachmeissel (quer)		75	720	23	70 447 02 072	
Breitmeissel (quer)		150	670	23	70 447 34 067	
Asphaltspaten (parallel)		150	700	23	70 447 65 070	
Stampfwerkzeug		200 x 200	670	34	70 447 95 067	

						
MSB MS 300 / 300 H						
Spitzmeissel		-	800	32	70 441 01 080	
Flachmeissel (quer)		85	800	32	70 441 02 080	
Breitmeissel (quer)		180	760	32	70 441 22 076	
Asphaltspaten (parallel)		180	790	32	70 441 53 079	
MSB MS 400 / 400 H						
Spitzmeissel		-	910	45	70 442 01 091	
Flachmeissel (quer)		95	910	45	70 442 02 091	
Breitmeissel (quer)		200	860	45	70 442 24 086	
Asphaltspaten (parallel)		200	890	45	70 442 55 089	
MSB MS 450 H / 460 / 460 H						
Spitzmeissel		-	920	51	70 433 01 092	
Flachmeissel (quer)		100	920	51	70 433 02 092	
Breitmeissel (quer)		200	870	51	70 433 24 087	
Stampfmeissel		-	920	51	70 433 00 092	
MSB MS 500 / 500 H / 520 / 520 H						
Spitzmeissel		-	1000	68	70 443 01 100	
Flachmeissel (quer)		110	1000	68	70 443 02 100	
Breitmeissel (quer)		240	940	68	70 443 26 094	
Stampfmeissel		-	920	68	70 443 00 092	
MSB MS 550 / 550 H						
Spitzmeissel		-	1100	87	70 449 01 110	
Flachmeissel (quer)		120	1100	87	70 449 02 110	
Stampfmeissel		-	1020	87	70 449 00 102	
MSB MS 600 / 600 H						
Spitzmeissel		-	1110	101	70 444 01 110	
Flachmeissel (quer)		130	1110	101	70 444 02 110	
Stampfmeissel		-	1020	101	70 444 00 102	

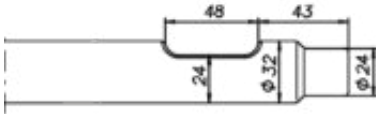
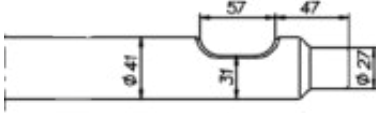
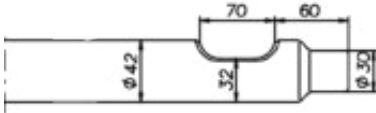
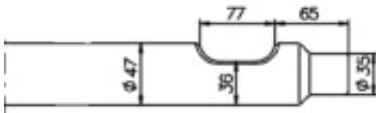
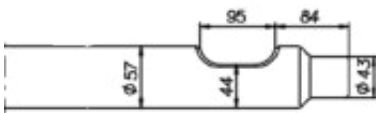
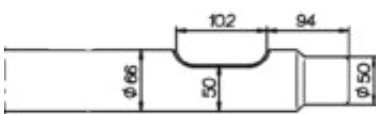

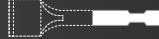

					solida - Nr.
Neuson NE 6					
Spitzmeissel		–	440	4	70 082 01 044
Flachmeissel (quer)		40	440	4	70 082 02 044
Breitmeissel (quer)		120	410	5	70 082 70 041
Asphaltspaten (parallel)		100	430	5	70 082 43 043
Neuson NE 8					
Spitzmeissel		–	440	5	70 080 01 044
Flachmeissel (quer)		42	440	5	70 080 02 044
Breitmeissel (quer)		120	390	5	70 080 70 039
Asphaltspaten (parallel)		100	400	5	70 080 43 040
Stampfwerkzeug		200 x 200	410	17	70 080 95 041
Neuson NE 12					
Spitzmeissel		–	460	6	70 076 01 046
Flachmeissel (quer)		45	460	6	70 076 02 046
Breitmeissel (quer)		140	430	6	70 076 18 043
Asphaltspaten (parallel)		115	440	6	70 076 83 044
Stampfwerkzeug		200 x 200	430	18	70 076 95 043
Neuson NE 16					
Spitzmeissel		–	540	9	70 079 01 054
Flachmeissel (quer)		54	540	9	70 079 02 054
Breitmeissel (quer)		140	500	9	70 079 18 050
Asphaltspaten (parallel)		115	510	9	70 079 83 051
Stampfwerkzeug		200 x 200	510	21	70 079 95 051
Neuson NE 22					
Spitzmeissel		–	600	14	70 077 01 060
Flachmeissel (quer)		62	600	14	70 077 02 060
Breitmeissel (quer)		150	540	14	70 077 34 054
Asphaltspaten (parallel)		130	560	14	70 077 69 056
Stampfwerkzeug		200 x 200	550	24	70 077 95 055
Neuson NE 28					
Spitzmeissel		–	650	19	70 078 01 065
Flachmeissel (quer)		69	650	19	70 078 02 065
Breitmeissel (quer)		180	610	19	70 078 22 061
Asphaltspaten (parallel)		200	660	20	70 078 55 066
Stampfwerkzeug		200 x 200	600	28	70 078 95 060

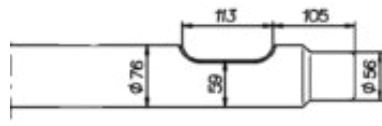
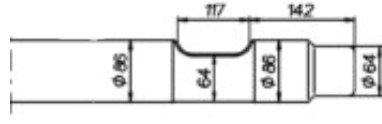
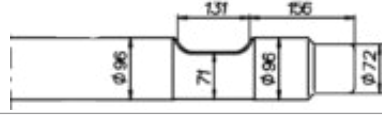
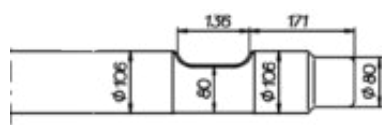
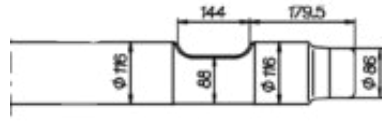
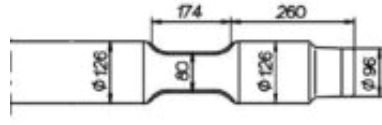
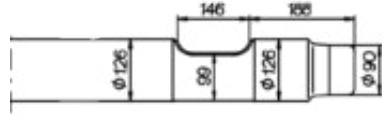
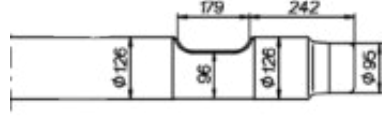
							
Neuson NE 36							
Spitzmeissel		–	700	23	70 081 01 070		
Flachmeissel (quer)		77	700	23	70 081 02 070		
Breitmeissel (quer)		150	650	23	70 081 34 065		
Asphaltspaten (parallel)		160	680	23	70 081 63 068		
Neuson NE 42							
Spitzmeissel		–	790	31	70 083 01 079		
Flachmeissel (quer)		85	790	31	70 083 02 079		
Breitmeissel (quer)		180	740	31	70 083 22 074		
Asphaltspaten (parallel)		180	770	31	70 083 53 077		
Neuson NE 50 / NE 300							
Spitzmeissel		–	850	41	70 074 01 085		
Flachmeissel (quer)		95	850	41	70 074 02 085		
Breitmeissel (quer)		200	800	41	70 074 24 080		
Asphaltspaten (parallel)		200	830	41	70 074 55 083		

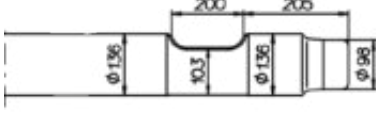
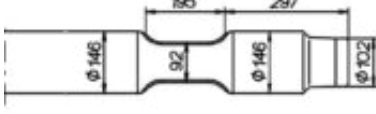
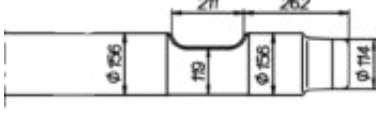
						solida - Nr.
NPK E-102						
Spitzmeissel		-	410	3,5		70 298 01 041
Flachmeissel (quer)		42	410	3,5		70 298 02 041
Breitmeissel (quer)		120	370	3,5		70 298 70 036
Asphaltspaten (parallel)		100	380	3,5		70 298 43 039
Stampfwerkzeug		200 x 200	380	16		70 254 95 038
NPK E-106						
Spitzmeissel		-	410	4		70 254 01 041
Flachmeissel (quer)		42	410	4		70 254 02 041
Breitmeissel (quer)		120	370	4		70 254 70 037
Asphaltspaten (parallel)		100	380	4		70 254 43 038
Stampfwerkzeug		200 x 200	380	16		70 254 95 038
NPK E-200 / GH 06						
Spitzmeissel		-	480	5		70 289 01 048
Flachmeissel (quer)		42	480	5		70 289 02 048
Breitmeissel (quer)		120	440	5		70 289 70 044
Asphaltspaten (parallel)		100	450	4		70 289 43 045
Stampfwerkzeug		200 x 200	450	17		70 289 95 045
NPK E-201 / GH 07						
Spitzmeissel		-	510	7		70 283 01 051
Flachmeissel (quer)		50	510	7		70 283 02 051
Breitmeissel (quer)		125	470	7		70 283 16 047
Asphaltspaten (parallel)		115	480	7		70 283 83 048
Stampfwerkzeug		200 x 200	480	18		70 283 95 048
NPK E-202 / GH 1						
Spitzmeissel		-	580	10		70 284 01 058
Flachmeissel (quer)		57	580	10		70 284 02 058
Breitmeissel (quer)		140	550	10		70 284 18 055
Asphaltspaten (parallel)		115	560	10		70 284 83 056
Stampfwerkzeug		200 x 200	550	21		70 284 95 055
NPK E-203 / GH 2						
Spitzmeissel		-	740	19		70 285 01 074
Flachmeissel (quer)		70	740	19		70 285 02 074
Breitmeissel (quer)		150	690	19		70 285 34 069
Asphaltspaten (parallel)		150	720	19		70 285 65 072
Stampfwerkzeug		200 x 200	690	28		70 285 95 069

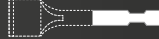
						solida - Nr.
NPK E-204 / GH 3						
Spitzmeissel		-	800	25	70 286 01 080	
Flachmeissel (quer)		80	800	25	70 286 02 080	
Breitmeissel (quer)		150	750	25	70 286 34 075	
Asphaltspaten (parallel)		160	780	25	70 286 63 078	
NPK E-205 / GH 4						
Spitzmeissel		-	890	37	70 287 01 089	
Flachmeissel (quer)		90	890	37	70 287 02 089	
Breitmeissel (quer)		180	840	37	70 287 22 084	
Asphaltspaten (parallel)		200	880	37	70 287 55 088	
NPK E-206						
Spitzmeissel		-	930	46	70 294 01 093	
Flachmeissel (quer)		100	930	46	70 294 02 093	
NPK E-207 / GH 6						
Spitzmeissel		-	1050	63	70 293 01 105	
Flachmeissel (quer)		106	1050	63	70 293 02 105	
Breitmeissel (quer)		200	1000	63	70 293 24 100	
Stampfmeissel		-	980	63	70 293 00 098	
NPK E-208						
Spitzmeissel		-	1160	89	70 292 01 116	
Flachmeissel (quer)		122	1160	89	70 292 02 116	
Stampfmeissel		-	1080	89	70 292 00 108	
NPK E-12-X / E-212						
Spitzmeissel		-	1100	91	70 274 01 110	
Flachmeissel (quer)		126	1100	91	70 274 02 110	
Stampfmeissel		-	1020	91	70 274 00 102	
NPK E-210-A						
Spitzmeissel		-	1180	102	70 279 01 118	
Flachmeissel (quer)		130	1180	102	70 279 02 118	
Stampfmeissel		-	1100	102	70 279 00 110	
NPK GH 9						
Spitzmeissel		-	1250	108	70 299 01 125	
Flachmeissel (quer)		130	1250	108	70 299 02 125	
Stampfmeissel		-	1170	108	70 299 00 117	

					solida - Nr.
NPK E-213 / E-213 A					
Spitzmeissel		-	1200	115	70 278 01 120
Flachmeissel (quer)		140	1200	115	70 278 02 120
Stampfmeissel		-	1100	115	70 278 00 110
NPK GH 10					
Spitzmeissel		-	1200	115	70 295 01 120
Flachmeissel (quer)		140	1200	115	70 295 02 120
Stampfmeissel		-	1100	115	70 295 00 110
NPK E-15-X / E-215					
Spitzmeissel		-	1200	112	70 275 01 120
Flachmeissel (quer)		140	1200	112	70 275 02 120
Stampfmeissel		-	1100	112	70 275 00 110
NPK E-18-X					
Spitzmeissel		-	1300	141	70 276 01 130
Flachmeissel (quer)		150	1300	141	70 276 02 130
Stampfmeissel		-	1200	141	70 276 00 120
NPK E-216					
Spitzmeissel		-	1300	143	70 290 01 130
Flachmeissel (quer)		150	1300	143	70 290 02 130
Stampfmeissel		-	1200	143	70 290 00 120
NPK E-218					
Spitzmeissel		-	1300	141	70 291 01 130
Flachmeissel (quer)		150	1300	141	70 291 02 130
Stampfmeissel		-	1200	141	70 291 00 120
NPK E-224 / E-24-X					
Spitzmeissel		-	1450	190	70 277 01 145
Flachmeissel (quer)		160	1450	190	70 277 02 145
Stampfmeissel		-	1350	190	70 277 00 135
NPK E-220					
Spitzmeissel		-	1400	181	70 288 01 140
Flachmeissel (quer)		160	1400	181	70 288 02 140
Stampfmeissel		-	1300	181	70 288 00 130

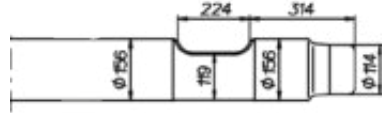
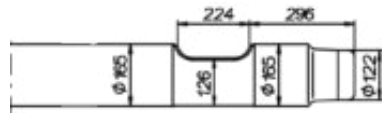
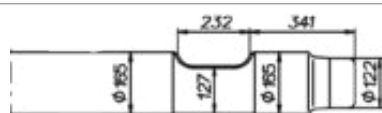
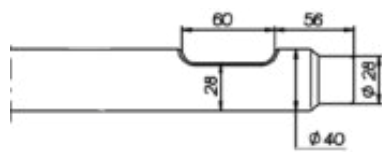
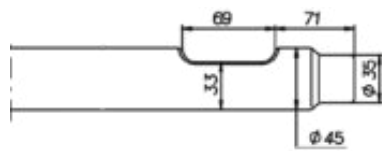
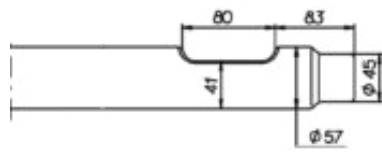
						solida - Nr.
NPK GH 15						
Spitzmeissel		-	1450	181		70 296 01 145
Flachmeissel (quer)		160	1450	181		70 296 02 145
Stampfmeissel		-	1350	181		70 296 00 135
NPK E-225						
Spitzmeissel		-	1520	224		70 280 01 152
Flachmeissel (quer)		165	1520	224		70 280 02 152
Stampfmeissel		-	1450	224		70 280 00 145
NPK GH 18						
Spitzmeissel		-	1490	215		70 297 01 149
Flachmeissel (quer)		165	1490	215		70 297 02 149
Stampfmeissel		-	1450	225		70 297 00 145
NPK H-06-X						
Spitzmeissel		-	480	5		70 271 01 048
Flachmeissel (quer)		42	480	5		70 271 02 048
Breitmeissel (quer)		120	440	5		70 271 70 044
Asphaltspaten (parallel)		100	450	5		70 271 43 045
Stampfwerkzeug		200 x 200	450	17		70 271 95 045
NPK H-08-X						
Spitzmeissel		-	480	5		70 252 01 048
Flachmeissel (quer)		45	480	5		70 252 02 048
Breitmeissel (quer)		120	440	5		70 252 70 044
Asphaltspaten (parallel)		100	450	5		70 252 43 045
Stampfwerkzeug		200 x 200	450	17		70 252 95 045
NPK H-1-XA						
Spitzmeissel		-	580	10		70 255 01 058
Flachmeissel (quer)		57	580	10		70 255 02 058
Breitmeissel (quer)		140	550	10		70 255 18 055
Asphaltspaten (parallel)		115	560	10		70 255 83 056
Stampfwerkzeug		200 x 200	550	21		70 255 95 055



NPK H-2-XA / XE

Spitzmeissel		-	600	14	70 268 01 060
Flachmeissel (quer)		65	600	14	70 268 02 060
Breitmeissel (quer)		150	550	14	70 268 34 055
Asphaltspaten (parallel)		130	570	14	70 268 69 057
Stampfwerkzeug		200 x 200	550	24	70 268 95 055

NPK H-3-XA/XE / H-2-X

Spitzmeissel		-	720	22	70 257 01 072
Flachmeissel (quer)		75	720	22	70 257 02 072
Breitmeissel (quer)		150	670	21	70 257 34 067
Asphaltspaten (parallel)		150	700	21	70 257 65 070
Stampfwerkzeug		200 x 200	670	31	70 257 95 067

NPK H-4-X / XE

Spitzmeissel		-	800	33	70 259 01 080
Flachmeissel (quer)		90	800	33	70 259 02 080
Breitmeissel (quer)		180	740	33	70 259 22 074
Asphaltspaten (parallel)		200	780	33	70 259 55 078

NPK H-5-X / 6-X

Spitzmeissel		-	930	48	70 260 01 093
Flachmeissel (quer)		100	930	48	70 260 02 093

NPK H-7-X

Spitzmeissel		-	930	57	70 261 01 093
Flachmeissel (quer)		106	930	57	70 261 02 093

NPK H-8-X





Spitzmeissel		-	930	58	70 262 01 093
Flachmeissel (quer)		106	930	58	70 262 02 093

NPK H-8-XA

Spitzmeissel		-	1000	70	70 269 01 100
Flachmeissel (quer)		118	1000	70	70 269 02 100
Stampfmeissel		-	920	70	70 269 00 092

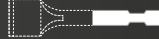
NPK H-10-X

Spitzmeissel		-	1100	85	70 256 01 098
Flachmeissel (quer)		126	1100	85	70 256 02 098

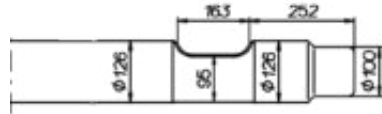
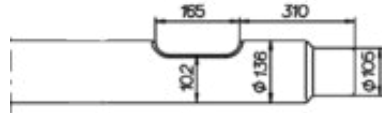
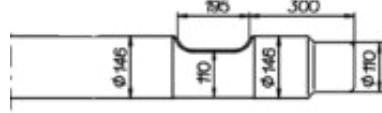
							_solida - Nr.
NPK H-10-XB / H-10-XE							
Spitzmeissel		-	1100	93	70 270 01 110		
Flachmeissel (quer)		126	1100	93	70 270 02 110		
Stampfmeissel		-	1020	93	70 270 00 102		
NPK H-12-X / H-12-XE							
Spitzmeissel		-	1200	115	70 265 01 120		
Flachmeissel (quer)		140	1200	115	70 265 02 120		
Stampfmeissel		-	1100	115	70 265 00 110		
NPK H-16-X / H-16-XE							
Spitzmeissel		-	1300	144	70 266 01 130		
Flachmeissel (quer)		150	1300	144	70 266 02 130		
Stampfmeissel		-	1200	144	70 266 00 120		



Rammer 111 / 155 / Sandvik BR 111 / 155

Spitzmeissel		-	360	4	70 587 01 036
Spitzmeissel		-	600	6	70 587 01 060
Flachmeissel (quer)		42	360	4	70 587 02 036
Breitmeissel (quer)		120	350	4	70 587 70 035
Asphaltspaten (parallel)		100	380	4	70 587 43 038

Rammer 255 / Sandvik BR 255

Spitzmeissel		-	410	4	70 584 01 041
Spitzmeissel		-	580	6	70 584 01 058
Flachmeissel (quer)		42	410	4	70 584 02 041
Breitmeissel (quer)		120	360	4	70 584 70 036
Asphaltspaten (parallel)		100	380	4	70 584 43 038
Stampfwerkzeug		200 x 200	420	16	70 584 95 042

Rammer Piccolo / S 18







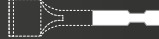

Spitzmeissel		-	410	4	70 573 01 041
Flachmeissel (quer)		42	410	4	70 573 02 041
Breitmeissel (quer)		120	370	4	70 573 70 037
Asphaltspaten (parallel)		100	380	4	70 573 43 038
Stampfwerkzeug		200 x 200	380	16	70 573 95 038

Rammer 222 / Sandvik BR 222

Spitzmeissel		-	410	4	70 588 01 041
Spitzmeissel		-	600	6	70 588 01 060
Flachmeissel (quer)		42	410	4	70 588 02 041
Breitmeissel (quer)		120	390	5	70 588 70 039
Asphaltspaten (parallel)		100	420	5	70 588 43 042
Stampfwerkzeug		200 x 200	420	17	70 588 95 042

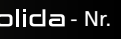
Rammer S 21 / Sandvik BR 321

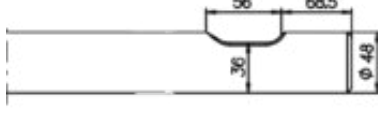
Spitzmeissel		-	480	6	70 566 01 048
Spitzmeissel		-	580	7	70 566 01 058
Flachmeissel (quer)		45	480	6	70 566 02 048
Breitmeissel (quer)		120	440	6	70 566 70 044
Asphaltspaten (parallel)		100	450	6	70 566 43 045
Stampfwerkzeug		200 x 200	450	17	70 566 95 045

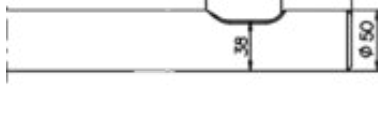
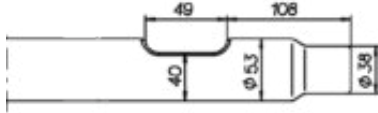
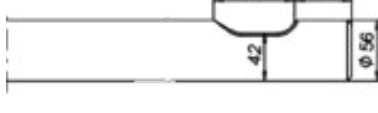
													
													
Rammer 355 / Sandvik BR 355													
Spitzmeissel		–	510	7	70 585 01 051								
Spitzmeissel		–	750	11	70 585 01 075								
Flachmeissel (quer)		48	510	7	70 585 02 051								
Breitmeissel (quer)		140	480	7	70 585 18 048								
Asphaltspaten (parallel)		115	490	7	70 585 83 049								
Stampfwerkzeug		200 x 200	480	19	70 585 95 048								
Rammer S 22 / Sandvik BR 422													
Spitzmeissel		–	510	8	70 576 01 051								
Spitzmeissel		–	750	11	70 576 01 075								
Flachmeissel (quer)		50	510	8	70 576 02 051								
Breitmeissel (quer)		140	480	7	70 576 18 048								
Asphaltspaten (parallel)		115	490	7	70 576 83 049								
Stampfwerkzeug		200 x 200	480	19	70 576 95 048								
Rammer 333 / Sandvik BR 333													
Spitzmeissel		–	510	8	70 589 01 051								
Spitzmeissel		–	700	10	70 589 01 070								
Flachmeissel (quer)		50	510	8	70 589 02 051								
Breitmeissel (quer)		140	480	8	70 589 18 048								
Asphaltspaten (parallel)		115	490	8	70 589 83 049								
Stampfwerkzeug		200 x 200	480	19	70 589 95 048								
Rammer S 20													
Spitzmeissel		–	530	8	70 452 01 053								
Flachmeissel (quer)		53	530	8	70 452 02 053								
Breitmeissel (quer)		140	500	8	70 452 18 050								
Asphaltspaten (parallel)		115	510	8	70 452 83 051								
Stampfwerkzeug		200 x 200	500	20	70 452 95 050								
Rammer 455 / Sandvik BR 455													
Spitzmeissel		–	580	11	70 581 01 058								
Flachmeissel (quer)		55	580	11	70 581 02 058								
Breitmeissel (quer)		140	550	11	70 581 18 055								
Asphaltspaten (parallel)		115	560	11	70 581 83 056								
Stampfwerkzeug		200 x 200	550	20	70 581 95 055								



solida - Nr.

Rammer S 23 / S 23 N / Sandvik BR 623

Spitzmeißel		-	700	16	70 565 01 070
Spitzmeißel		-	810	19	70 565 01 081
Flachmeißel (quer)		65	700	16	70 565 02 070
Breitmeißel (quer)		150	550	13	70 565 34 055
Asphaltspaten (parallel)		130	570	13	70 565 69 057
Stampfwerkzeug		200 x 200	650	26	70 565 95 065

Rammer S 25 / Sandvik BR 825

Spitzmeißel		-	740	20	70 567 01 074
Flachmeißel (quer)		70	740	20	70 567 02 074
Breitmeißel (quer)		150	690	20	70 567 34 069
Asphaltspaten (parallel)		150	720	20	70 567 65 072
Stampfwerkzeug		200 x 200	690	30	70 567 95 069

Rammer 555 / Sandvik BR 555

Spitzmeißel		-	670	21	70 596 01 067
Flachmeißel (quer)		75	670	21	70 596 02 067
Breitmeißel (quer)		150	620	21	70 596 34 062
Asphaltspaten (parallel)		150	650	21	70 596 65 065
Stampfwerkzeug		200 x 200	670	32	70 596 95 067

Rammer 777 / Sandvik BR 777









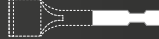

Spitzmeißel		-	800	28	70 592 01 080
Flachmeißel (quer)		80	800	28	70 592 02 080
Breitmeißel (quer)		180	760	28	70 592 22 076
Asphaltspaten (parallel)		180	790	28	70 592 53 079





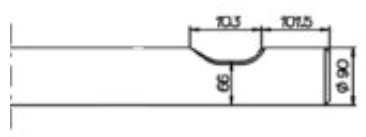
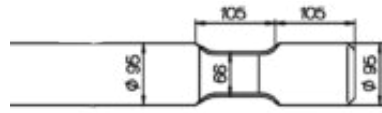
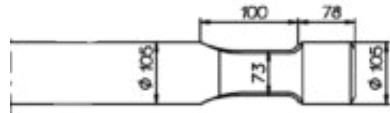
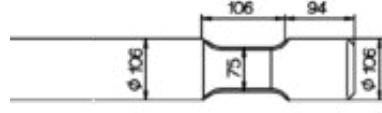
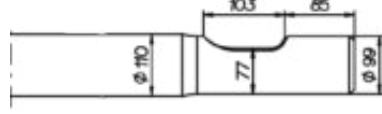
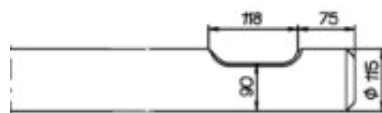

Rammer S 27 / Sandvik BR 927



Spitzmeißel		-	840	33	70 577 01 084
Flachmeißel (quer)		85	840	33	70 577 02 084
Breitmeißel (quer)		180	840	35	70 577 22 084
Asphaltspaten (parallel)		200	880	36	70 577 55 088



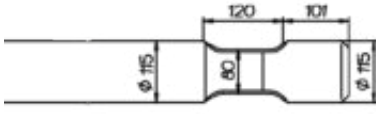
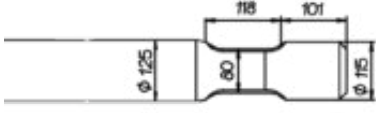
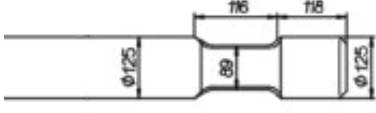
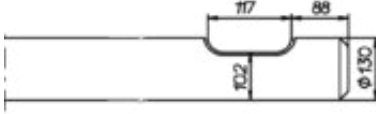
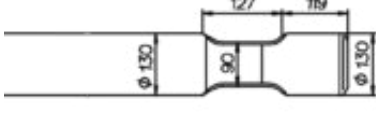
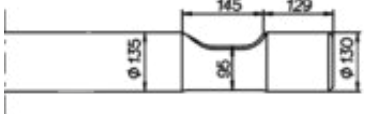

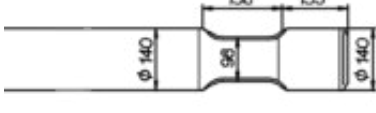

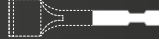

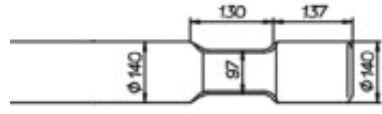
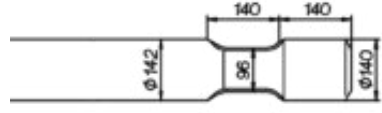
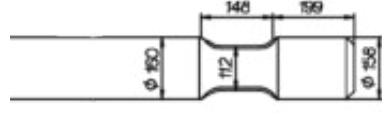
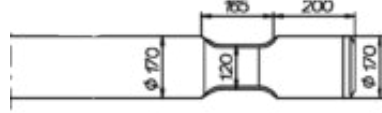
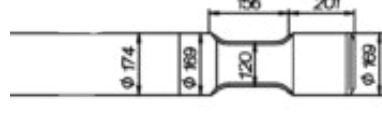
Rammer S 26 / S 26 N

Spitzmeißel		-	890	38	70 454 01 089
Flachmeißel (quer)		90	890	38	70 454 02 089
Breitmeißel (quer)		180	840	38	70 454 22 084
Asphaltspaten (parallel)		180	870	38	70 454 53 087

									
					kg				solida - Nr.
Rammer 999 / Sandvik BR 999									
Spitzmeissel		-	900	40					70 593 01 090
Flachmeissel (quer)		90	900	40					70 593 02 090
Breitmeissel (quer)		180	840	40					70 593 22 084
Asphaltspaten (parallel)		180	870	40					70 593 55 087
Rammer S 29 / Sandvik BR 1229									
Spitzmeissel		-	900	45					70 574 01 090
Spitzmeissel		-	1000	51					70 574 01 100
Flachmeissel (quer)		95	900	45					70 574 02 090
Breitmeissel (quer)		200	800	42					70 574 24 080
Asphaltspaten (parallel)		200	830	42					70 574 55 083
Rammer 1533 / Sandvik BR 1533									
Spitzmeissel		-	1050	65					70 599 01 105
Flachmeissel (quer)		106	1050	65					70 599 02 105
Breitmeissel (quer)		200	1000	65					70 599 24 100
Stampfmeissel		-	980	65					70 599 00 098
Rammer E 64 / Sandvik BR 2064									
Spitzmeissel		-	1050	65					70 569 01 105
Flachmeissel (quer)		106	1050	65					70 569 02 105
Breitmeissel (quer)		200	1000	65					70 569 24 100
Stampfmeissel		-	980	65					70 569 00 098
Rammer S 52									
Spitzmeissel		-	900	59					70 455 01 090
Flachmeissel (quer)		115	900	59					70 455 02 090
Breitmeissel (quer)		240	840	59					70 455 26 084
Stampfmeissel		-	860	59					70 455 00 086
Rammer S 54									
Spitzmeissel		-	1060	78					70 560 01 106
Flachmeissel (quer)		115	1060	78					70 560 02 106
Stampfmeissel		-	980	78					70 560 00 098
Rammer E 63 / Sandvik BR 2063									
Spitzmeissel		-	1000	70					70 586 01 100
Flachmeissel (quer)		115	1000	70					70 586 02 100
Stampfmeissel		-	980	75					70 586 00 098

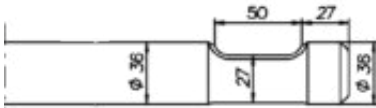
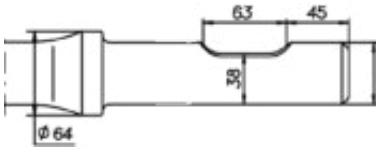
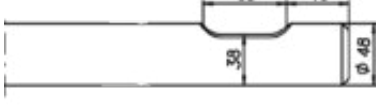
   		solida - Nr.			
Rammer E 66 / E 66 N / S 55 / Sandvik BR 2266					
Spitzmeissel		-	1060	77	70 578 01 106
Flachmeissel (quer)		115	1060	77	70 578 02 106
Stampfmeissel		-	980	77	70 578 00 098
Rammer E 65 / Sandvik BR 2265					
Spitzmeissel		-	1100	93	70 594 01 110
Flachmeissel (quer)		125	1100	93	70 594 02 110
Stampfmeissel		-	1020	93	70 594 00 102
Rammer M 14 / Sandvik BR 2214					
Spitzmeissel		-	1100	97	70 595 01 110
Flachmeissel (quer)		125	1100	97	70 595 02 110
Stampfmeissel		-	1020	97	70 595 00 102
Rammer S 56					
Spitzmeissel		-	1100	103	70 561 01 110
Flachmeissel (quer)		130	1100	103	70 561 02 110
Stampfmeissel		-	1020	103	70 561 00 102
Rammer E 68 / Sandvik BR 2568					
Spitzmeissel		-	1100	101	70 571 01 110
Flachmeissel (quer)		130	1100	101	70 571 02 110
Stampfmeissel		-	1020	101	70 571 00 102
Rammer E 69 / Sandvik BR 2577					
Spitzmeissel		-	1200	117	70 597 01 120
Flachmeissel (quer)		135	1200	117	70 597 02 120
Stampfmeissel		-	1100	117	70 597 00 110
Rammer S 83					
Spitzmeissel		-	1200	128	70 568 01 120
Flachmeissel (quer)		140	1200	128	70 568 02 120
Stampfmeissel		-	1100	128	70 568 00 110
Rammer G 80					
Spitzmeissel		-	1200	129	70 575 01 120
Flachmeissel (quer)		140	1200	129	70 575 02 120
Stampfmeissel		-	1100	129	70 575 00 110

					_solida - Nr.
Rammer M 18 / Sandvik BR 2518					
Spitzmeissel		-	1200	128	70 591 01 120
Flachmeissel (quer)		140	1200	128	70 591 02 120
Stampfmeissel		-	1100	128	70 591 00 110
Rammer G 88 / Sandvik BR 3088 / BR 3288					
Spitzmeissel		-	1200	135	70 598 01 120
Flachmeissel (quer)		142	1200	135	70 598 02 120
Stampfmeissel		-	1100	135	70 598 00 110
Rammer G 90 / Sandvik BR 3890					
Spitzmeissel		-	1400	198	70 580 01 140
Flachmeissel (quer)		160	1400	198	70 580 02 140
Stampfmeissel		-	1250	192	70 580 00 125
Rammer G 100 / Sandvik BR 4510					
Spitzmeissel		-	1450	232	70 572 01 145
Flachmeissel (quer)		170	1450	232	70 572 02 145
Stampfmeissel		-	1350	232	70 572 00 135
Rammer G 110 / Sandvik BR 4511					
Spitzmeissel		-	1450	247	70 583 01 145
Flachmeissel (quer)		180	1450	247	70 583 02 145
Stampfmeissel		-	1350	247	70 583 00 135

											
Rotair OLS 50											
Spitzmeissel		-	400	3	70 744 01 040						
Flachmeissel (quer)		42	400	3	70 744 02 040						
Breitmeissel (quer)		115	440	4	70 744 14 044						
Asphaltspaten (parallel)		125	440	4	70 744 45 044						
Stampfwerkzeug		200 x 200	380	15	70 744 95 038						
Rotair OL 90											
Spitzmeissel		-	480	7	70 890 01 048						
Flachmeissel (quer)		50	480	7	70 890 02 048						
Breitmeissel (quer)		140	450	7	70 890 18 045						
Asphaltspaten (parallel)		115	460	7	70 890 83 046						
Stampfwerkzeug		200 x 200	450	18	70 890 95 045						
Rotair OLS 95											
Spitzmeissel		-	510	7	70 894 01 051						
Flachmeissel (quer)		50	510	7	70 894 02 051						
Breitmeissel (quer)		140	480	7	70 894 18 048						
Asphaltspaten (parallel)		115	490	7	70 894 83 049						
Stampfwerkzeug		200 x 200	470	19	70 894 95 047						
Rotair OL 130 / OLS 160											
Spitzmeissel		-	530	9	70 892 01 053						
Flachmeissel (quer)		55	530	9	70 892 02 053						
Breitmeissel (quer)		140	500	9	70 892 18 050						
Asphaltspaten (parallel)		115	510	9	70 892 83 051						
Stampfwerkzeug		200 x 200	500	20	70 892 95 050						
Rotair OL 180 / OLS 260											
Spitzmeissel		-	740	20	70 891 01 074						
Flachmeissel (quer)		70	740	20	70 891 02 074						
Breitmeissel (quer)		150	690	20	70 891 34 069						
Asphaltspaten (parallel)		150	720	20	70 891 65 072						
Stampfwerkzeug		200 x 200	690	29	70 891 95 069						
Rotair OL 250 / OLS 330											
Spitzmeissel		-	700	24	70 893 01 070						
Flachmeissel (quer)		80	700	24	70 893 02 070						
Breitmeissel (quer)		180	660	24	70 893 22 066						
Asphaltspaten (parallel)		180	690	24	70 893 53 069						











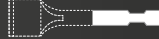

Rotair OLS 450 / OLS 550

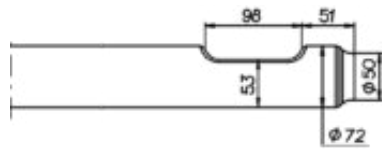



Spitzmeissel		-	720	26	70 895 01 072
Flachmeissel (quer)		82	720	26	70 895 02 072
Breitmeissel (quer)		180	680	26	70 895 22 068
Asphaltspaten (parallel)		180	710	26	70 895 53 071

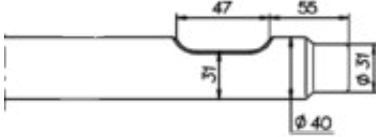
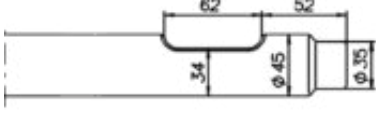
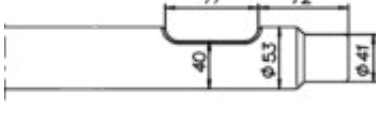
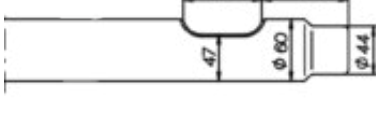
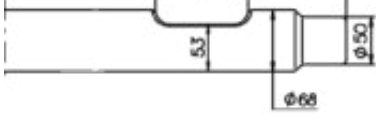
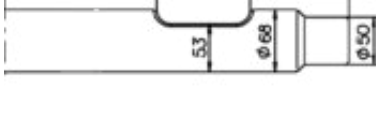

				kg	solida - Nr.
Socomec DMS 50					
Spitzmeissel		-	480	6	70 330 01 048
Flachmeissel (quer)		45	480	6	70 330 02 048
Breitmeissel (quer)		120	440	6	70 330 70 044
Asphaltspaten (parallel)		100	450	6	70 330 43 045
Stampfwerkzeug		200 x 200	450	18	70 330 95 045
Socomec DMS 95					
Spitzmeissel		-	520	6	70 322 01 052
Flachmeissel (quer)		45	520	6	70 322 02 052
Breitmeissel (quer)		120	480	6	70 322 70 048
Asphaltspaten (parallel)		100	490	6	70 322 43 049
Stampfwerkzeug		200 x 200	490	18	70 322 95 049
Socomec DMS 150 / 160 / 165					
Spitzmeissel		-	530	9	70 328 01 053
Flachmeissel (quer)		55	530	9	70 328 02 053
Breitmeissel (quer)		140	500	9	70 328 18 050
Asphaltspaten (parallel)		115	510	9	70 328 83 051
Stampfwerkzeug		200 x 200	500	21	70 328 95 050
Socomec DMS 210					
Spitzmeissel		-	600	13	70 335 01 060
Flachmeissel (quer)		62	600	13	70 335 02 060
Breitmeissel (quer)		150	550	13	70 335 34 055
Asphaltspaten (parallel)		130	570	13	70 335 69 057
Stampfwerkzeug		200 x 200	550	24	70 335 95 055
Socomec DMS 220					
Spitzmeissel		-	600	14	70 331 01 060
Flachmeissel (quer)		65	600	14	70 331 02 060
Breitmeissel (quer)		150	550	14	70 331 34 055
Asphaltspaten (parallel)		130	570	14	70 331 69 057
Stampfwerkzeug		200 x 200	550	25	70 331 95 055
Socomec DMS 260 / 270					
Spitzmeissel		-	740	20	70 327 01 074
Flachmeissel (quer)		70	740	20	70 327 02 074
Breitmeissel (quer)		150	690	20	70 327 34 069
Asphaltspaten (parallel)		150	720	20	70 327 65 072
Stampfwerkzeug		200 x 200	690	31	70 327 95 069

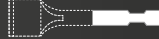
    		_solida - Nr.			
Socomec DMS 310 / 330					
Spitzmeissel		–	720	21	70 321 01 072
Flachmeissel (quer)		75	720	21	70 321 02 072
Breitmeissel (quer)		150	670	21	70 321 34 067
Asphaltspaten (parallel)		150	700	21	70 321 65 070
Stampfwerkzeug		200 x 200	670	33	70 321 95 067
Socomec DMS 680 / 740 / 850					
Spitzmeissel		–	900	45	70 333 01 090
Flachmeissel (quer)		95	900	45	70 333 02 090
Breitmeissel (quer)		200	850	45	70 333 24 085
Asphaltspaten (parallel)		200	890	45	70 333 55 089

						solida - Nr.
Soosan SB 10						
Spitzmeissel		–	420	4		70 304 01 042
Flachmeissel (quer)		42	420	4		70 304 02 042
Breitmeissel (quer)		120	420	4		70 304 70 042
Asphaltspaten (parallel)		100	420	4		70 304 43 042
Stampfwerkzeug		200 x 200	400	16		70 304 95 040
Soosan SB 20 / SB 20 II						
Spitzmeissel		–	480	6		70 307 01 048
Flachmeissel (quer)		45	480	6		70 307 02 048
Breitmeissel (quer)		120	440	6		70 307 70 044
Asphaltspaten (parallel)		100	450	6		70 307 43 045
Stampfwerkzeug		200 x 200	450	17		70 307 95 045
Soosan SB 30 / SB 30 II						
Spitzmeissel		–	550	9		70 306 01 055
Flachmeissel (quer)		55	550	9		70 306 02 055
Breitmeissel (quer)		140	520	9		70 306 18 052
Asphaltspaten (parallel)		115	530	9		70 306 83 053
Stampfwerkzeug		200 x 200	520	20		70 306 95 052
Soosan SB 35 / SB 35 II						
Spitzmeissel		–	600	12		70 689 01 060
Flachmeissel (quer)		60	600	12		70 689 02 060
Breitmeissel (quer)		150	550	12		70 689 34 055
Asphaltspaten (parallel)		130	570	12		70 689 69 057
Stampfwerkzeug		200 x 200	550	23		70 689 95 055
Soosan SB 40 / SB 40 II						
Spitzmeissel		–	740	19		70 686 01 074
Flachmeissel (quer)		70	740	19		70 686 02 074
Breitmeissel (quer)		150	690	19		70 686 34 069
Asphaltspaten (parallel)		150	720	19		70 686 65 072
Stampfwerkzeug		200 x 200	690	30		70 686 95 069
Soosan SB 4						
Spitzmeissel		–	740	19		70 300 01 074
Flachmeissel (quer)		70	740	19		70 300 02 074
Breitmeissel (quer)		150	690	19		70 300 34 069
Asphaltspaten (parallel)		150	720	19		70 300 65 072
Stampfwerkzeug		200 x 200	690	30		70 300 95 069

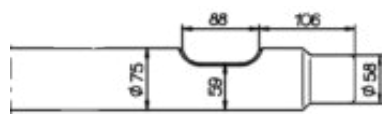
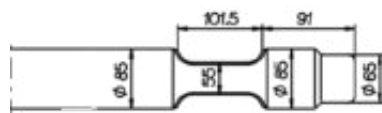
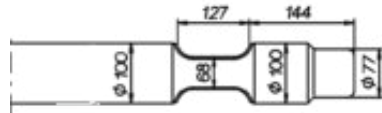
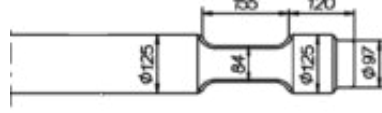
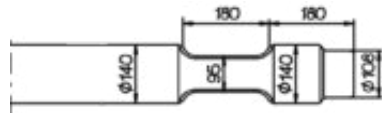
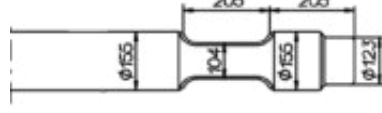
						
	solida - Nr.					
Soosan SB 43 / SB 43 II						
Spitzmeissel		-	800	26	70 693 01 080	
Flachmeissel (quer)		75	800	26	70 693 02 080	
Breitmeissel (quer)		150	750	25	70 693 34 075	
Asphaltspaten (parallel)		150	780	26	70 693 65 078	
Stampfwerkzeug		200 x 200	770	38	70 693 95 077	
Soosan SB 45						
Spitzmeissel		-	800	31	70 683 01 080	
Flachmeissel (quer)		85	800	31	70 683 02 080	
Breitmeissel (quer)		180	740	30	70 683 22 074	
Asphaltspaten (parallel)		200	780	31	70 683 55 078	
Soosan SB 50						
Spitzmeissel		-	1000	52	70 684 01 100	
Flachmeissel (quer)		100	1000	52	70 684 02 100	
Breitmeissel (quer)		200	950	52	70 684 24 095	
Stampfmeissel		-	930	52	70 684 00 093	
Soosan SB 60						
Spitzmeissel		-	1150	99	70 301 01 115	
Flachmeissel (quer)		125	1150	99	70 301 02 115	
Stampfmeissel		-	1070	99	70 301 00 107	
Soosan SB 81						
Spitzmeissel		-	1270	131	70 302 01 127	
Flachmeissel (quer)		140	1270	131	70 302 02 127	
Stampfmeissel		-	1170	131	70 302 00 117	
Soosan SB 121						
Spitzmeissel		-	1450	190	70 303 01 145	
Flachmeissel (quer)		155	1450	190	70 303 02 145	
Stampfmeissel		-	1350	190	70 303 00 135	



Toku TNB 08 M

Spitzmeissel		–	450	4	70 142 01 045
Flachmeissel (quer)		42	450	4	70 142 02 045
Breitmeissel (quer)		120	410	4	70 142 70 041
Asphaltspaten (parallel)		100	420	4	70 142 43 042
Stampfwerkzeug		200 x 200	450	16	70 142 95 045

Toku TNB 1 M

Spitzmeissel		–	480	5	70 143 01 048
Flachmeissel (quer)		45	480	5	70 143 02 048
Breitmeissel (quer)		120	440	5	70 143 70 044
Asphaltspaten (parallel)		100	450	5	70 143 43 045
Stampfwerkzeug		200 x 200	450	17	70 143 95 045

Toku TNB 1 E / TNB 2 M

Spitzmeissel		–	510	7	70 701 01 051
Flachmeissel (quer)		50	510	7	70 701 02 051
Breitmeissel (quer)		140	480	7	70 701 18 048
Asphaltspaten (parallel)		115	490	7	70 701 83 049
Stampfwerkzeug		200 x 200	480	19	70 701 95 048

Toku TNB 2 E / TNB 3 M bis 2011/12





Spitzmeissel		–	600	11	70 702 01 060
Flachmeissel (quer)		58	600	11	70 702 02 060
Breitmeissel (quer)		150	560	11	70 702 34 056
Asphaltspaten (parallel)		130	580	11	70 702 69 058
Stampfwerkzeug		200 x 200	560	22	70 702 95 056

Toku TNB 2 E / TNB 3 M ab 2011/12

Spitzmeissel		–	600	11	70 146 01 060
Flachmeissel (quer)		58	600	11	70 146 02 060
Breitmeissel (quer)		150	560	11	70 146 34 056
Asphaltspaten (parallel)		130	580	11	70 146 69 058
Stampfwerkzeug		200 x 200	560	22	70 146 95 056

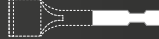
Toku TNB 3 E

Spitzmeissel		–	700	16	70 140 01 070
Flachmeissel (quer)		65	700	16	70 140 02 070
Breitmeissel (quer)		150	650	16	70 140 34 065
Asphaltspaten (parallel)		130	670	16	70 140 69 067
Stampfwerkzeug		200 x 200	650	26	70 140 95 065

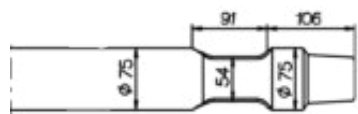
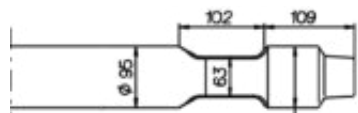
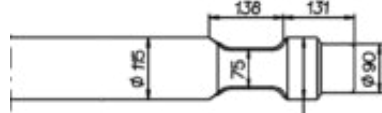
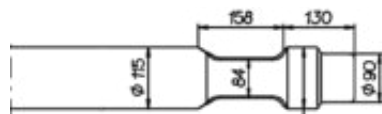
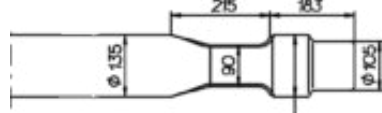
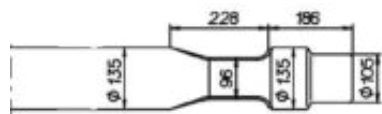
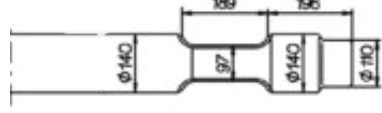
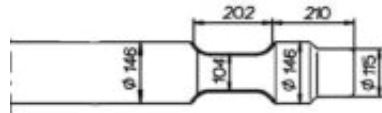
						solida - Nr.
Toku TNB 4 E / 5 M						
Spitzmeissel		-	720	22		70 704 01 072
Flachmeissel (quer)		75	720	22		70 704 02 072
Breitmeissel (quer)		150	670	22		70 704 34 067
Asphaltspaten (parallel)		150	700	22		70 704 65 070
Stampfwerkzeug		200 x 200	670	30		70 704 95 067
Toku TNB 5 E / 6 E / 6,5 E						
Spitzmeissel		-	840	40		70 703 01 084
Flachmeissel (quer)		95	840	40		70 703 02 084
Breitmeissel (quer)		200	800	40		70 703 24 080
Asphaltspaten (parallel)		200	830	40		70 703 55 083
Toku TNB 7E / 8E / 10E						
Spitzmeissel		-	940	65		70 705 01 094
Flachmeissel (quer)		115	940	65		70 705 02 094
Stampfmeissel		-	860	65		70 705 00 086
Toku TNB 100						
Spitzmeissel		-	1050	74		70 144 01 105
Flachmeissel (quer)		115	1050	74		70 144 02 105
Stampfmeissel		-	980	74		70 144 00 098
Toku TNB 14 E / 16 E						
Spitzmeissel		-	1200	112		70 707 01 120
Flachmeissel (quer)		135	1200	112		70 707 02 120
Stampfmeissel		-	1100	112		70 707 00 110
Toku TNB 150 / 151						
Spitzmeissel		-	1200	113		70 915 01 120
Flachmeissel (quer)		135	1200	113		70 915 02 120
Stampfmeissel		-	1100	113		70 915 00 110
Toku TNB 190						
Spitzmeissel		-	1200	123		70 145 01 120
Flachmeissel (quer)		140	1200	123		70 145 02 120
Stampfmeissel		-	1100	123		70 145 00 110
Toku TNB 220 / 230						
Spitzmeissel		-	1300	145		70 141 01 130
Flachmeissel (quer)		145	1300	145		70 141 02 130
Stampfmeissel		-	1200	145		70 141 00 120



Toyo THBB 51 / Takeuchi TKB 51

Spitzmeissel		-	410	4	70 829 01 041
Flachmeissel (quer)		42	410	4	70 829 02 041
Breitmeissel (quer)		120	440	5	70 829 70 044
Asphaltspaten (parallel)		100	450	5	70 829 43 045
Stampfwerkzeug		200 x 200	380	16	70 829 95 038

Toyo THBB 50 / Takeuchi TKB 50

Spitzmeissel		-	480	6	70 820 01 048
Flachmeissel (quer)		45	480	6	70 828 02 048
Breitmeissel (quer)		120	440	6	70 828 70 044
Asphaltspaten (parallel)		100	450	6	70 828 43 045
Stampfwerkzeug		200 x 200	450	17	70 820 95 045

Toyo THBB 71 / Takeuchi TKB 71

Spitzmeissel		-	480	6	70 820 01 048
Flachmeissel (quer)		45	480	6	70 820 02 048
Breitmeissel (quer)		120	440	6	70 820 70 044
Asphaltspaten (parallel)		100	450	6	70 820 43 045
Stampfwerkzeug		200 x 200	450	17	70 820 95 045

Toyo THBB 101 / Takeuchi TKB 101





Spitzmeissel		-	580	10	70 826 01 058
Flachmeissel (quer)		57	580	10	70 826 02 058
Breitmeissel (quer)		140	550	10	70 826 18 055
Asphaltspaten (parallel)		115	560	10	70 826 83 056
Stampfwerkzeug		200 x 200	550	21	70 826 95 055



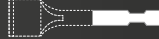

Toyo THBB 301 / Takeuchi TKB 301



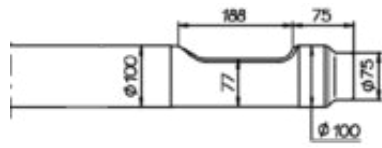
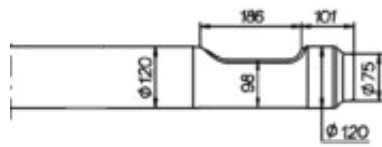
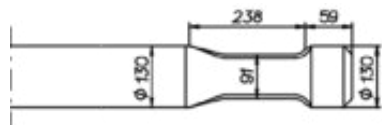
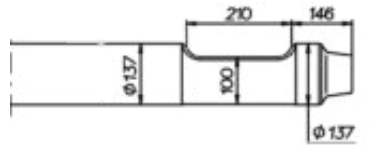
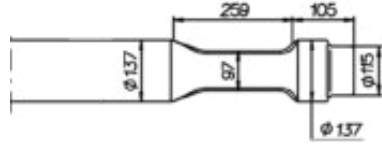
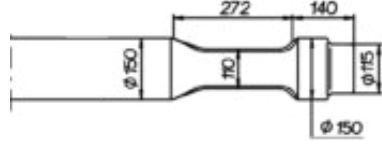

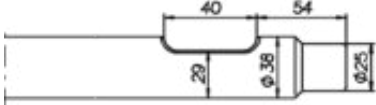
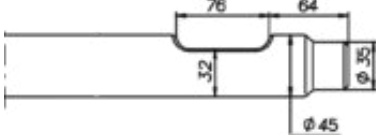
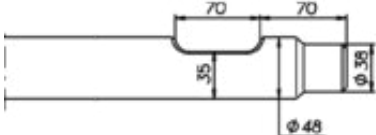
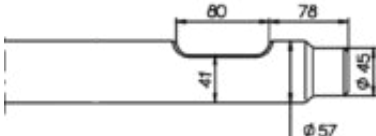
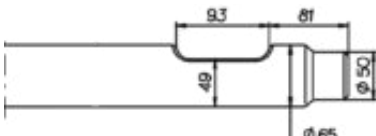

Spitzmeissel		-	740	19	70 825 01 074
Flachmeissel (quer)		70	740	19	70 825 02 074
Breitmeissel (quer)		150	690	19	70 825 34 069
Asphaltspaten (parallel)		150	720	19	70 825 65 072
Stampfwerkzeug		200 x 200	690	29	70 825 95 069

Toyo THBB 401 / Takeuchi TKB 401

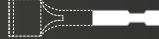
Spitzmeissel		-	900	32	70 822 01 090
Flachmeissel (quer)		80	900	32	70 822 02 090
Breitmeissel (quer)		180	860	32	70 822 22 086
Asphaltspaten (parallel)		180	890	32	70 822 53 089

						_solida - Nr.
Toyo THBB 801 / Takeuchi TKB 801						
Spitzmeissel		-	1000	53	70 824 01 100	
Flachmeissel (quer)		100	1000	53	70 824 02 100	
Breitmeissel (quer)		200	950	53	70 824 24 095	
Stampfmeissel		-	930	53	70 824 00 093	
Toyo THBB 1101 / Takeuchi TKB 1101						
Spitzmeissel		-	1150	95	70 830 01 115	
Flachmeissel (quer)		120	1150	95	70 830 02 115	
Stampfmeissel		-	1070	95	70 830 00 107	
Toyo THBB 1401 / Takeuchi TKB 1401						
Spitzmeissel		-	1100	100	70 833 01 110	
Flachmeissel (quer)		130	1100	100	70 833 02 110	
Stampfmeissel		-	1020	100	70 833 00 102	
Toyo THBB 1400 / Takeuchi TKB 1400						
Spitzmeissel		-	1200	118	70 823 01 120	
Flachmeissel (quer)		140	1200	118	70 823 02 120	
Stampfmeissel		-	1100	118	70 823 00 110	
Toyo THBB 1600 / Takeuchi TKB 1600						
Spitzmeissel		-	1250	127	70 831 01 125	
Flachmeissel (quer)		140	1250	127	70 831 02 125	
Stampfmeissel		-	1170	127	70 831 00 117	
Toyo THBB 2000 / Takeuchi TKB 2000						
Spitzmeissel		-	1350	162	70 827 01 135	
Flachmeissel (quer)		150	1350	162	70 827 02 135	
Stampfmeissel		-	1250	162	70 827 00 125	

						kg	solida - Nr.
Vistarini VH 60 / HBS 6							
Spitzmeissel		-	410	4	70 780 01 041		
Flachmeissel (quer)		42	410	4	70 780 02 041		
Breitmeissel (quer)		120	360	4	70 780 70 036		
Asphaltspaten (parallel)		100	380	4	70 780 43 038		
Stampfwerkzeug		200 x 200	420	16	70 780 95 042		
Vistarini VH 90 / VHX 90 / HBS 9							
Spitzmeissel		-	450	5	70 781 01 045		
Flachmeissel (quer)		45	450	5	70 781 02 045		
Breitmeissel (quer)		120	410	5	70 781 70 041		
Asphaltspaten (parallel)		100	420	5	70 781 43 042		
Stampfwerkzeug		200 x 200	470	17	70 781 95 047		
Vistarini VH 120 / VHX 120 / HBS 12							
Spitzmeissel		-	510	7	70 950 01 051		
Flachmeissel (quer)		50	510	7	70 950 02 051		
Breitmeissel (quer)		140	480	7	70 950 18 048		
Asphaltspaten (parallel)		115	490	7	70 950 83 049		
Stampfwerkzeug		200 x 200	480	18	70 950 95 048		
Vistarini VH 160 / VHX 200 / HBS 20							
Spitzmeissel		-	580	10	70 782 01 058		
Flachmeissel (quer)		57	580	10	70 782 02 058		
Breitmeissel (quer)		140	550	10	70 782 18 055		
Asphaltspaten (parallel)		115	560	10	70 782 83 056		
Stampfwerkzeug		200 x 200	550	21	70 782 95 055		
Vistarini VH 220 / 240 / 250 / VHX 250 / 300 / 330 / 331 / HBS 25 / 31							
Spitzmeissel		-	540	12	70 783 01 054		
Flachmeissel (quer)		65	540	12	70 783 02 054		
Breitmeissel (quer)		150	490	12	70 783 34 049		
Asphaltspaten (parallel)		130	510	12	70 783 69 051		
Stampfwerkzeug		200 x 200	490	22	70 783 95 049		

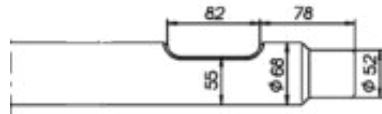
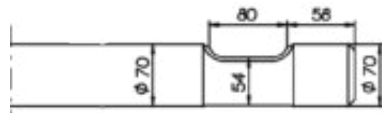
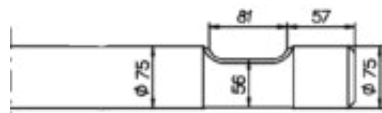
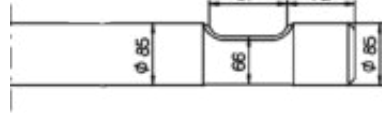
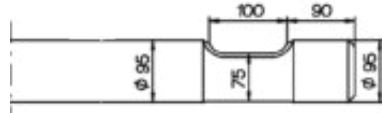
									solida - Nr.
Wimmer W 115									
Spitzmeissel		–	480	4,5	70 439 01 048				
Flachmeissel (quer)		45	480	4,5	70 439 02 048				
Breitmeissel (quer)		120	440	4,5	70 439 70 044				
Asphaltspaten (parallel)		100	450	4,5	70 439 43 045				
Stampfwerkzeug		200 x 200	450	16	70 439 95 045				
Wimmer WH 4									
Spitzmeissel		–	740	19	70 438 01 074				
Flachmeissel (quer)		68	740	19	70 438 02 074				
Breitmeissel (quer)		150	690	19	70 438 34 069				
Asphaltspaten (parallel)		150	720	19	70 438 65 072				
Stampfwerkzeug		200 x 200	690	31	70 438 95 069				
Wimmer W 220 / WH 5									
Spitzmeissel		–	740	20	70 440 01 074				
Flachmeissel (quer)		70	740	20	70 440 02 074				
Breitmeissel (quer)		150	690	20	70 440 34 069				
Asphaltspaten (parallel)		150	720	20	70 440 65 072				
Stampfwerkzeug		200 x 200	690	31	70 440 95 069				
Wimmer W 275 / WH 6									
Spitzmeissel		–	720	23	70 447 01 072				
Flachmeissel (quer)		75	720	23	70 447 02 072				
Breitmeissel (quer)		150	670	23	70 447 34 067				
Asphaltspaten (parallel)		150	700	23	70 447 65 070				
Stampfwerkzeug		200 x 200	670	34	70 447 95 067				
Wimmer W 330 / WH 8									
Spitzmeissel		–	800	32	70 441 01 080				
Flachmeissel (quer)		85	800	32	70 441 02 080				
Breitmeissel (quer)		180	760	32	70 441 22 076				
Asphaltspaten (parallel)		180	790	32	70 441 53 079				
Wimmer W 440									
Spitzmeissel		–	910	45	70 442 01 091				
Flachmeissel (quer)		95	910	45	70 442 02 091				
Breitmeissel (quer)		200	860	45	70 442 24 086				
Asphaltspaten (parallel)		200	890	45	70 442 55 089				



Wimmer W 550 / WH 17

Spitzmeissel		-	1000	68	70 443 01 100
Flachmeissel (quer)		114	1000	68	70 443 02 100
Breitmeissel (quer)		240	940	68	70 443 26 094
Stampfmeissel		-	920	68	70 443 00 092

Wimmer W 600 / WH 22

Spitzmeissel		-	1100	87	70 449 01 110
Flachmeissel (quer)		120	1100	87	70 449 02 110
Stampfmeissel		-	1020	87	70 449 00 102

Wimmer W 660 / WH 26

Spitzmeissel		-	1110	101	70 444 01 110
Flachmeissel (quer)		130	1110	101	70 444 02 110
Stampfmeissel		-	1020	101	70 444 00 102

pneumatictools



**WIR FERTIGEN NACH
IHREN WÜNSCHEN!**

Sprechen Sie uns auf weitere
Sorten, Typen, Längen und
Ausführungen einfach an!

T +49 2191 3715-0

LEGENDE



= Arbeitsseite



= F : F = Fläche : Fläche



= R : F = Rippe : Fläche

(= Serienmäßige Stellung der
Schneide zum Einsteckende)



= Breite



= Nutzlänge



= Gewicht

_solida - Nr.

= Bestellnummer

_solida® GERMANY

NUR WER SEIN ZIEL KENNT, FINDET DEN WEG!

Die mobilen Pneumatikhämmer sind multifunktionell. Gestein und Asphalt bilden hier jedoch immer noch den bevorzugten Einsatzbereich.

Beispielhafte Einsteckwerkzeuge

Breitflachmeissel gebogen

Überzeugt durch die ergonomisch gebogene Arbeitsseite für optimalen Arbeitswinkel. Mit extra großer Breite und zusätzlicher Schneidwirkung. Zum universellen Abtragen von Materialien in größerem Umfang, z. B. Estrich. Für leichten Asphaltaufbruch. Ideal für Arbeiten in leicht gefrorenem Boden.

Flachspaten

Der Schneidespezialist für den Straßenbau. Schneidet Asphalt oder hartes Erdreich.

Grabspaten

Zum universellen Graben in Erdreich und lockerem Gestein. Zusätzlich schneidet er zuverlässig starken Asphalt.

Asphaltschneider

Der breite Spezialist mit gebogener Blattkante. Für schweren Asphaltaufbruch, in der Oberflächen-sanierung. Mit großer Spaltkraft.

Stampfwerkzeug mit geschmiedeter Platte

Für alle Verdichtungsarbeiten von Kies, Sand, Schüttgut und Erdreich und zur Reparatur von Asphaltausbrüchen. Inklusive Adapter. Platte auswechselbar.



Flachspaten

**AUCH MIT IHREM
EINSTECKENDE!**

Unsere Arbeitsseiten liefern
wir mit nahezu allen Ein-
steckenden. Fragen Sie uns.
Wir beraten Sie gerne.
Rufen Sie uns an unter

T +49 2191 3715-0

Ein wahres Wort auch für Einsteckwerkzeuge. Denn auch im Straßenbau, der Paradedisziplin für den Einsatz von Pneumatikhämmern, macht das richtige Einsteckwerkzeug den Arbeitsfortschritt aus. Nicht nur von Baustoff und Bauverfahren ist der Einsatz abhängig. Häufig auch vom Wetter. Wussten Sie, dass es Einsteckwerkzeuge gibt, die auch leicht gefrorenem Boden die kalte Schulter zeigen? Gerade im Bereich der Straßeninstandsetzung sind die Anforderungen hoch. Geringe Einbaukosten und Minimierung von Verkehrsbehinderung gehören dazu. Mit der richtigen Werkzeugauswahl kann die präzise Sanierung optimal vorbereitet werden.

Moderne Einsteckwerkzeuge haben eine besondere Schneidwirkung, beschleunigen den Output durch extra große Breite, sind ergonomisch gebogen, finden Einsatz in Asphalt oder auch Schotter. Oder sie dienen der Verdichtung und sind damit ideal für kleinflächige Patches bei Schlaglöchern und Ausplatzungen.

SOLIDA bietet viele Wege, den Umgang mit dem Hammer zu optimieren. Das ist unser Ziel.



Spitzmeissel

Der Universalmeissel für Abbrucharbeiten. Optimal zum Erstellen von Öffnungen und Durchbrüchen in Beton, Mauerwerk aus Ziegel und vielen weiteren Werkstoffen. Einsatz zum Abbau von lockerem Gestein. Spitze pyramidal geschmiedet für die Keilwirkung beim Abtrag. Mit der konzentrierten Kraftübertragung auf die Spitze ideal zum Aufbrechen, Durchbrechen und Abbrechen von Material.



Flachmeissel

Universell im Einsatz, mit zusätzlicher Schneid- bzw. Brechwirkung. Für Auf- und Abbrucharbeiten. Optimal zum Erstellen von Öffnungen und Durchbrüchen in Beton, Ziegel und vielen weiteren Werkstoffen. Einsatz zum Abbau von losem Gestein. Auch zum Abtragen von Mörtelresten und Betonüberstand.



Breitflachmeissel gerade

Mit extra großer Breite und zusätzlicher Schneidwirkung. Zum universellen Abtragen von Materialien in größerem Umfang, z. B. Estrich. Für leichten Asphaltaufbruch. Ideal für Arbeiten in leicht gefrorenem Boden.

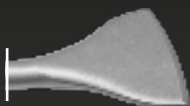

Breitflachmeissel gebogen

Überzeugt durch die ergonomisch gebogene Arbeitsseite für optimalen Arbeitswinkel. Mit extra großer Breite und zusätzlicher Schneidwirkung. Zum universellen Abtragen von Materialien in größerem Umfang, z. B. Estrich. Für leichten Asphaltaufbruch. Ideal für Arbeiten in leicht gefrorenem Boden.



Flachspaten

Der Schneidespezialist für den Straßenbau. Schneidet Asphalt oder hartes Erdreich.



Grabspaten

Zum universellen Graben in Erdreich und lockerem Gestein. Zusätzlich schneidet er zuverlässig starken Asphalt.



Asphaltschneider

Der breite Spezialist mit gebogener Blattkante. Für schweren Asphaltaufbruch, in der Oberflächenreparatur. Mit großer Spaltkraft.



Stampfwerkzeug mit geschmiedeter Platte

Für alle Verdichtungsarbeiten von Kies, Sand, Schüttgut und Erdreich und zur Reparatur von Asphaltausbrüchen. Inklusive Adapter. Platte auswechselbar.



Rammglocke









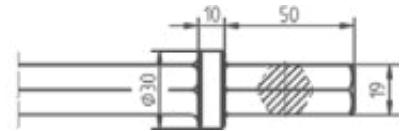













Zum Einschlagen von Rohren und Pfählen in den Boden. Außen- \varnothing max. 100 mm, Innen- \varnothing max. 80 mm.

Alle Einsteckwerkzeuge von SOLIDA sind nur für ihren bestimmungsgemäßen Gebrauch in den mit den passenden Werkzeugaufnahmen versehenen Maschinen bestimmt und geeignet. Darüber hinaus sind die Bedienungsanleitungen und Sicherheitshinweise der Maschinenhersteller zu beachten. Für diesbezüglichen Fehlgebrauch übernimmt SOLIDA keine Haftung.

	∅ 19 x 50 mm	132
	∅ 22 x 82 mm	133 – 134
	∅ 22 x 108 mm	135
	∅ 25 x 108 mm	136
	∅ 28 x 152 mm	137
	∅ 28 x 160 mm	138
	∅ 32 x 152 mm	139
	∅ 32 x 160 mm	140
	∅ 12,5 mm – ∅ 14,3 x 50 mm	141
	∅ 12,4 mm – ∅ 15 x 55 mm	142
	∅ 14,8 mm – ∅ 17,5 x 60 mm, Bund ∅ 30 mm	143
	∅ 17 mm – ∅ 20 x 60 mm, Bund ∅ 30 mm	144
	∅ 25 x 75 mm, Länge bis zu 1 Meter	145
	∅ 25 x 75 mm, Länge über 1 Meter	146
	∅ 25 x 75 mm, Bund □ 38 mm	147
	∅ 27 x 80 mm, Bund □ 34 mm	148









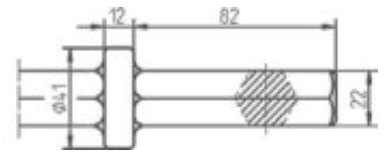











Einsteckende
 19 x 50 mm



												solida - Nr.
Spitzmeissel									-	250	0,7	1100 010 025
									-	350	1	1100 010 035
									-	450	1,2	1100 010 045
									-	1000	2,5	1100 010 100
									-	1500	3,7	1100 010 150
Flachmeissel									25	250	0,7	1100 011 025
									25	350	1	1100 011 035
									25	450	1,2	1100 011 045
									25	600	1,6	1100 011 060
									25	1000	2,5	1100 011 100
									25	1500	3,7	1100 011 150
Breitflachmeissel								60	200	0,8	1100 030 020	
Breitflachmeissel, gebogen								60	200	0,8	1100 031 020	
Breitflachmeissel								95	210	0,8	1100 060 021	
Breitflachmeissel, gebogen								95	210	0,8	1100 061 021	
Rammglocke									Ø 60	290	2,6	1100 807 029
Stampfwerkzeug									120 x 120	260	2,5	1100 652 026
									150 x 150	260	3,7	1100 653 026









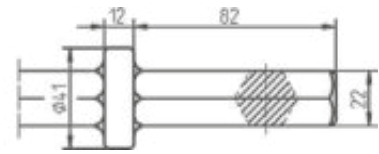





Einsteckende
Ø 22 x 82 mm



						
	Spitzmeissel	-	-	380	1,5	1102 010 038
		-	-	450	1,8	1102 010 045
	Spitzmeissel	-	-	600	2,25	1102 010 060
		-	-	800	2,92	1102 010 080
		-	-	1000	3,6	1102 010 100
		-	-	1200	4,2	1102 010 120
		-	-	1500	5,2	1102 010 150
		-	-	2000	6,9	1102 010 200
		-	-	2500	8,4	1102 010 250
	Flachmeissel		23	380	1,5	1102 011 038
			23	450	1,8	1102 011 045
	Flachmeissel		28	600	2,25	1102 011 060
			28	800	2,9	1102 011 080
			28	1000	3,6	1102 011 100
			28	1200	4,2	1102 011 120
			28	1500	5,2	1102 011 150
			28	2000	6,9	1102 011 200
			28	2500	8	1102 011 250
			28	3000	10,1	1102 011 300
			28	3500	11	1102 011 350









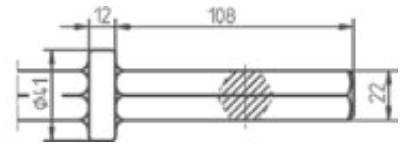





Einsteckende
 22 x 82 mm



					solida - Nr.
 Breitflachmeißel		75	360	1,8	1102 050 036
 Asphaltspaten		100	350	2,2	1102 095 035
 Flachspaten		120	400	2,8	1102 120 040
 Grabspaten		75	400	2,8	1102 150 040
 Rammglocke		Ø 60	290	2,9	1102 807 029
 Stampfwerkzeug		120 x 120	260	2,8	1102 652 026
		150 x 150	260	4	1102 653 026

Einsteckende
□ 22 x 108 mm



					solida - Nr.
		-	450	1,9	1105 010 045
		25	450	1,9	1105 011 045
		75	360	1,9	1105 050 036
		100	350	2,4	1105 095 035
		Ø 60	290	3	1105 807 029
		120 x 120	260	2,9	1105 652 026
		150 x 150	260	4,1	1105 653 026



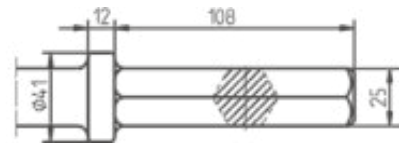





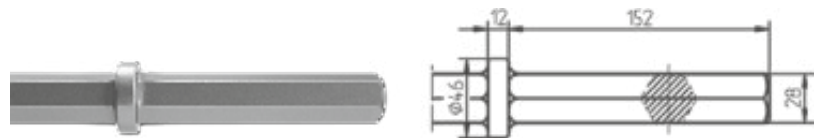



Einsteckende
⊙ 25 x 108 mm



						solida - Nr.
	Spitzmeißel		-	380	2	1106 010 038
			-	450	2,3	1106 010 045
	Spitzmeißel		-	600	3	1106 010 060
			-	800	3,9	1106 010 080
			-	1000	4,7	1106 010 100
			-	1500	6,9	1106 010 150
	Flachmeißel		28	380	2	1106 011 038
			28	450	2,3	1106 011 045
	Flachmeißel		30	1000	4,8	1106 011 100
			30	1500	7	1106 011 150
	Breitflachmeißel		75	360	2,3	1106 050 036
	Flachspaten		120	400	3,3	1106 120 040
	Asphaltschneider		115	270	2,5	1106 189 027
	Grabspaten		75	400	3	1106 150 040
	Rammglocke		Ø 60	290	4	1106 807 029
			Ø 80	290	4,7	1106 808 029
	Stampfwerkzeug		150 x 150	260	8	1106 655 026
			200 x 200	260	11,9	1106 656 026

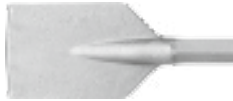







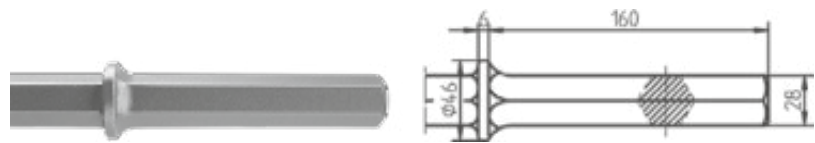







Einsteckende
Ø 28 x 152 mm



					kg	solida - Nr.
	Spitzmeissel		-	450	3,5	1107 010 045
	Flachmeissel		30	450	3,5	1107 011 045
	Grabspaten		75	400	3,5	1107 150 040
	Flachspaten		125	350	3,4	1107 129 035
	Rammglocke		Ø 60	290	4,6	1107 807 029
			Ø 80	290	5,3	1107 808 029
	Stampfwerkzeug		150 x 150	260	8,6	1107 655 026
			200 x 200	260	12,5	1107 656 026









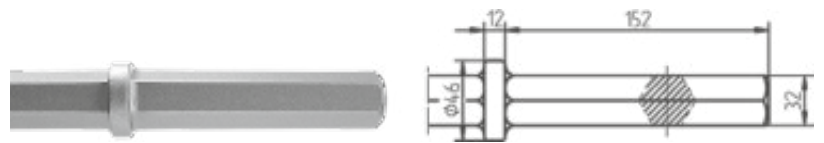







Einsteckende
 28 x 160 mm



					solida - Nr.
		-	400	3	1108 010 040
		-	450	3,2	1108 010 045
		30	400	3	1108 011 040
		30	450	3,2	1108 011 045
		75	400	3,5	1108 150 040
		125	350	3,6	1108 129 035
		85	360	2,8	1108 170 036
		Ø 60	290	4,6	1108 807 029
		Ø 80	290	5,3	1108 808 029
		150 x 150	260	8,6	1108 655 026
		200 x 200	260	12,5	1108 656 026









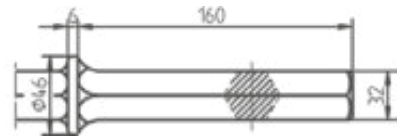











Einsteckende
32 x 152 mm



					solida - Nr.
		-	400	3,5	1109 010 040
		-	450	4	1109 010 045
		32	400	3,5	1109 011 040
		32	450	4	1109 011 045
		85	360	3,5	1109 170 036
		75	400	3,8	1109 150 040
		125	350	3,8	1109 127 035
		115	270	3,5	1109 188 027
		Ø 60	290	4,9	1109 807 029
		Ø 80	290	5,6	1109 808 029
		150 x 150	260	8,9	1109 655 026
		200 x 200	260	12,8	1109 656 026







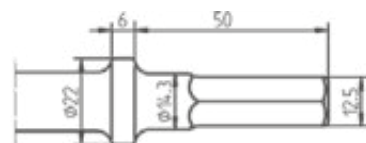

Einsteckende
 32 x 160 mm



					solida - Nr.
		-	400	3,5	1110 010 040
		-	450	4	1110 010 045
		32	400	3,5	1110 011 040
		32	450	4	1110 011 045
		75	75 x 400	3,9	1110 150 040
		125	125 x 350	4,3	1110 127 035
		115	115 x 270	3,5	1110 188 027
		125	400	4,8	1110 131 040
		Ø 60	290	4,9	1110 807 029
		Ø 80	290	5,6	1110 808 029
		150 x 150	260	9	1110 655 026
		200 x 200	260	13	1110 656 026









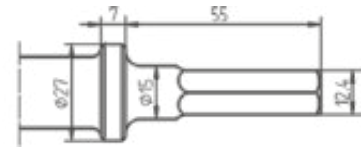

Einsteckende
 \square 12,5 mm – \varnothing 14,3 x 50 mm



				kg	solida - Nr.	
	Spitzmeissel	–	200	0,3	1050 010 020	
	Flachmeissel		15	200	0,3	1050 011 020
			20	200	0,3	1050 012 020
	Spatmeissel		40	200	0,4	1050 022 020









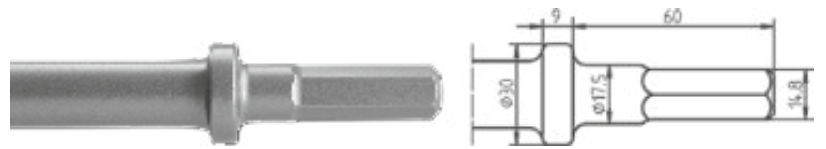



Einsteckende
 \square 12,4 mm – \varnothing 15 x 55 mm



						solida - Nr.
	Spitzmeissel		–	190	0,5	1052 010 019
	Flachmeissel		20	190	0,5	1052 011 019
	Breitflachmeissel		50	180	0,6	1052 020 018

Einsteckende
 ∅ 14,8 mm – ∅ 17,5 x 60 mm,
 Bund ∅ 30 mm



					solida - Nr.	
	Spitzmeissel	-	260	0,7	1053 010 026	
		-	350	0,9	1053 010 035	
		-	450	1,2	1053 010 045	
	Flachmeissel		23	260	0,7	1053 011 026
			23	350	0,9	1053 011 035
			23	450	1,2	1053 011 045
	Breitflachmeissel		60	200	0,7	1053 030 020
	Breitflachmeissel		95	210	0,8	1053 060 021



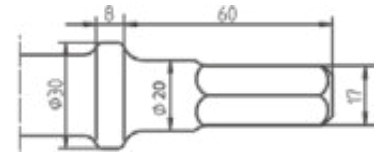



Einsteckende
 □ 17 mm – Ø 20 x 60 mm,
 Bund Ø 30 mm

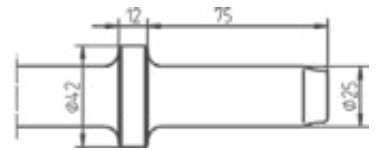

				kg	solida - Nr.	
	Spitzmeissel	–	220	0,8	1066 010 022	
		–	350	1,2	1066 010 035	
		–	450	1,5	1066 010 045	
	Flachmeissel		24	220	0,8	1066 011 022
			24	350	1,2	1066 011 035
			24	450	1,5	1066 011 045
	Breitflachmeissel		60	200	0,8	1066 030 020
			60	450	1,4	1066 030 045
	Breitflachmeissel		95	210	0,8	1066 060 021







Einsteckende
Ø 25 x 75 mm,
Länge bis zu 1 Meter

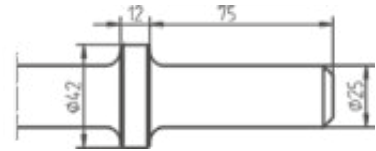

					solida - Nr.
 Spitzmeissel		–	350	1,5	1004 010 035
		–	400	1,7	1004 010 040
		–	450	2	1004 010 045
		–	500	2,3	1004 010 050
		–	600	2,5	1004 010 060
		–	800	3,4	1004 010 080
		–	1000	4	1004 010 100
 Flachmeissel		25	350	1,5	1004 011 035
		25	400	1,7	1004 011 040
		25	450	2	1004 011 045
		25	1000	4,1	1004 011 100
 Flachspaten		120	400	3,1	1004 120 040









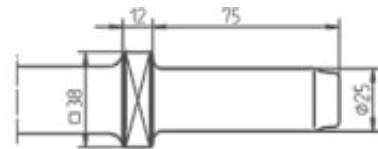

Einsteckende
Ø 25 x 75 mm,
Länge über 1 Meter



					solida - Nr.
 Spitzmeissel		-	1200	4,9	1037 010 120
		-	1500	6,4	1037 010 150
		-	1800	7,2	1037 010 180
		-	2000	8,1	1037 010 200
		-	2500	9,9	1037 010 250
		-	3000	11,8	1037 010 300
		-	4000	15,6	1037 010 400
 Flachmeissel		25	1500	6,4	1037 011 150
		25	2000	8,1	1037 011 200









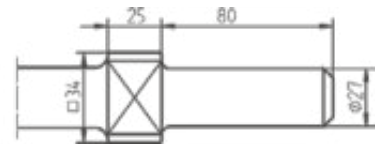



Einsteckende
Ø 25 x 75 mm, Bund □ 38 mm



						
					kg	solida - Nr.
	Spitzmeissel		-	450	2	1361 010 045
	Flachmeissel		25	450	2	1361 011 045
	Flachspaten		120	400	3,2	1361 120 040
	Rammglocke		Ø 60	290	3,9	1361 807 029
			Ø 80	290	4,6	1361 808 029
	Stampfwerkzeug		150 x 150	260	7,9	1361 655 026
			200 x 200	260	11,8	1361 656 026

Einsteckende
 $\varnothing 27 \times 80 \text{ mm}$, Bund $\square 34 \text{ mm}$



						solida - Nr.
	Spitzmeissel		–	400	2,15	1362 010 040
	Flachmeissel		28	400	2,15	1362 011 040
	Breitflachmeissel		75	360	2,4	1362 050 036
	Flachspaten		120	400	3,4	1362 120 040
	Grabspaten		75	400	2,95	1362 150 040
	Rammglocke		$\varnothing 60$	300	4	1362 807 030
			$\varnothing 80$	300	4,7	1362 808 030
	Stampfwerkzeug		150 x 150	270	8	1362 655 027
			200 x 200	270	11,9	1362 656 027

electrotools

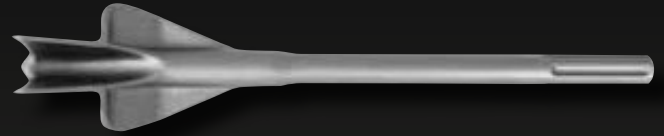

LEGENDE



= Arbeitsseite



= F : F = Fläche : Fläche



= R : F = Rippe : Fläche
(= Serienmäßige Stellung der
Schneide zum Einsteckende)



= Breite



= Gesamtlänge



= Nutzlänge



= Gewicht

solida - Nr.

= Bestellnummer

**WIR FERTIGEN NACH
IHREN WÜNSCHEN!**

Sprechen Sie uns auf weitere
Sorten, Typen, Längen und
Ausführungen einfach an!

T +49 2191 3715-0

solida®
GERMANY

ES MUSS NICHT IMMER SPITZ ODER FLACH SEIN.

Beispielhafte Einsteckwerkzeuge

Uni-Kanalmeissel mit Gleiter

Der 2in1-Meissel für das Erstellen von Kanälen und das anschließende Ausstemmen von Verteiler- und Steckdosen ohne Werkzeugwechsel. Die Gleiterführung ermöglicht verschiedene Kanaltiefen. Für den Einsatz in Kalksandstein, Ziegel, Bimsstein, mit und ohne Putz, in Neubau und Sanierung.

Spachtelmeissel

Der Entferner unter den Meisseln mit extra breitem, flexiblem Spachtelende. Breitflächiger Abtrag von Kleberresten und Beschichtungen. Entfernen von Teppichboden, PVC, Linoleum, Vinyl, Kork u. a. als Fliesen oder Auslegeware. Spachtelblatt auswechselbar.

Erdnagelintreiber

Zum schnellen, maschinellen Einschlagen von Erdnägeln/Erdleitern für Blitzableiter.

Spatmeissel

Mit extra großer Breite und zusätzlicher Schneidwirkung. Zum universellen Abtragen von Materialien in größerem Umfang, z. B. Putz oder Estrich.

Sonderwerkzeuge laufen den Klassikern immer mehr den Rang ab. Die Spezialisten unter den Einsteckwerkzeugen werden dann eingesetzt, wenn sie hochwirtschaftlich die Handarbeit automatisieren können. Dabei greifen immer mehr Branchen auf die breite Auswahl an Spezialwerkzeugen zurück. So nutzen Elektriker nicht nur Werkzeuge zur Kanalerstellung, sondern auch Erdnagelintreiber beim Erstellen von Blitzeinrichtungen.

Bodenleger sehen im Spachtelmeißel das richtige Werkzeug, um die unterschiedlichsten Bodenbelege zu entfernen.

Gerade bei schweren Böden werden Spitz-, Schaufel- und Asphaltspaten den manuellen vorgezogen. Sie bieten Entlastung für den Menschen, beschleunigen die Arbeitsgänge und steigern damit die Produktivität.

Auch bei der Abtragung von Estrich hat der Spitz- und Flachmeißel eine zeitgemäße Ergänzung erhalten. Der Spatmeißel trägt Materialien wie Estrich und auch Putz einfach schneller ab.

Die wendigen Hämmer im Elektrobereich unterstützen immer mehr Arbeitsschritte der unterschiedlichen Gewerke und entlasten von der Handarbeit.

WELCHER IST DER OPTIMALE?

Unsere Spezialisten beraten Sie schnell und einfach am Telefon. Einsatzzweck nennen und wir zeigen Ihnen das optimale Einsteckwerkzeug:

T +49 2191 3715-0



Spachtelmeißel

Spitzmeissel

Der Allrounder. Für unterschiedlichste Aufbrucharbeiten und das Erstellen von Öffnungen und Durchbrüchen in Beton, Mauerwerk aus Ziegel und vielen weiteren Werkstoffen. Einsatz zum Abbau von losem Gestein. Spitze pyramidal geschmiedet für die Keilwirkung beim Abtrag. Mit der konzentrierten Kraftübertragung auf die Spitze ideal zum Aufbrechen, Durchbrechen und Abbrechen von Material.

Spitzmeissel mit Sprengwirkung

Maximierte Abtragsleistung. Für unterschiedlichste Aufbrucharbeiten und das Erstellen von Öffnungen und Durchbrüchen in Beton, Mauerwerk aus Ziegel und vielen weiteren Werkstoffen. Einsatz zum Abbau von losem Gestein. Die Geometrie der Spitze ist spiralförmig gefertigt. Der Meissel dringt schneller ins Material und erhöht den Abtrag. Entstehender Staub wird effektiv abtransportiert, der Meissel setzt sich nicht fest.

Flachmeissel

Universell im Einsatz, mit zusätzlicher Schneid- bzw. Brechwirkung. Für Auf- und Abbrucharbeiten. Optimal zum Erstellen von Öffnungen und Durchbrüchen in Beton, Ziegel und vielen weiteren Werkstoffen. Einsatz zum Abbau von lockerem Gestein. Auch zum Abtragen von Mörtelresten und Betonüberstand.

Spatmeissel/Breitmeissel

Mit extra großer Breite und zusätzlicher Schneidwirkung. Zum universellen Abtragen von Materialien in größerem Umfang, z. B. Putz oder Estrich.

Spatmeissel/Breitmeissel gebogen

Überzeugt durch die ergonomisch gebogene Arbeitsseite für optimalen Arbeitswinkel. Mit extra großer Breite und zusätzlicher Schneidwirkung. Zum universellen Abtragen von Materialien in größerem Umfang, z. B. Putz und Estrich.

Spaten

Der Schneidespezialist für die Oberflächensanierung im Straßenbau. Schneidet Asphalt oder hartes Erdreich.

Spitzspaten

Für den Einsatz im Garten- und Landschaftsbau. Erleichtert die Arbeit in schwerem Boden wie Graben in Lehm, verdichtetem Kies, Schotter oder Schlamm.

Schaufelspaten

Für den Einsatz im Garten- und Landschaftsbau. Erleichtert die Arbeit in schwerem Boden wie Graben in Lehm, verdichtetem Kies, Schotter oder Schlamm. Für den breitflächigeren Einsatz auch im Straßenbau.

Asphaltspaten

Der breite Spezialist mit gerader Blattkante. Für hartes Erdreich und den Straßenbau, zur Oberflächensanierung von Asphalt.

Asphaltschneider

Der breite Spezialist mit gebogener Blattkante. Für hartes Erdreich und den Straßenbau, zur Oberflächensanierung von Asphalt. Mit großer Spalt- und Schneidkraft.

Fliesenmeissel

Mit langem Blatt und optimalem Arbeitswinkel zum Entfernen von Fliesen/Kacheln und Platten von Wand, Boden, Treppen etc.

**Kanalmeissel**

Zum Ziehen von Kanälen in unterschiedlichem Mauerwerk wie Kalksandstein, Ziegel, Bimsstein.

**Uni-Kanalmeissel mit Gleiter**

Der 2in1-Meissel für das Erstellen von Kanälen und das anschließende Ausstemmen von Verteiler- und Steckdosen ohne Werkzeugwechsel. Die Gleiterführung ermöglicht verschiedene Kanaltiefen. Für den Einsatz in Kalksandstein, Ziegel, Bimsstein, mit und ohne Putz, in Neubau und Sanierung.

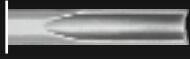
**Hohlmeissel**

Der Spezialist für das Ziehen von schmalen Kanälen in Beton.

**Zahneisen/Fugenmeissel**

Für das Entfugen/Entfernen von Fugen/Mörtel zur Sanierung von Mauerwerk.

**Zahneisen/Fugenmeissel mit Hartmetall**

Der Profi mit Hartmetalleinsätzen. Für das Entfugen/Entfernen von Fugen/Mörtel zur Sanierung von Mauerwerk. Zum Herausnehmen von intakten Mauersteinen und zum Entfernen von Kacheln und Verputzlagen. Einsatz auch zum Entfernen von überflüssigem Beton und Glätten von Flächen.

**Erdnagelintreiber**

Zum schnellen, maschinellen Einschlagen von Erdnägeln/Erdleitern für Blitzableiter.

**Rammglocke**

Zum Einschlagen von Rohren und Pfählen in den Boden. Außen- \varnothing max. 100 mm, Innen- \varnothing max. 80 mm.

**Stocker**

Zum Aufrauen von Oberflächen bei der Sanierung von Beton und Asphalt. Und zur Entfernung von Betonüberständen.

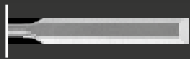
**Stechbeitel**

Zur maschinellen Bearbeitung von Holz. Zum schnellen, kraftschonenden Holzabtrag.

**Stampfwerkzeug mit geschmiedeter Platte**

Für alle Verdichtungsarbeiten von Kies, Sand, Schüttgut und Erdreich und zur Reparatur von Asphaltausbrüchen. Inklusive Adapter. Platte auswechselbar.

**Spachtelmeissel**

Der Entferner unter den Meisseln mit extra breitem, flexiblem Spachtelblatt. Breitflächiger Abtrag von Kleberresten und Beschichtungen. Entfernen von Teppichboden, PVC, Linoleum, Vinyl, Kork u. a. als Fliesen oder Auslegeware. Spachtelblatt auswechselbar (komplettes Ersatzteil-Set).

**Hammerbohrer**









Unterschiedliche Kopfgeometrien mit Hartmetalleinsätzen erzeugen besonders schnellen Vortrieb im Material und damit hervorragende Bohrleistung. Die Spiralform ist ausgelegt für optimalen Bohrmehlauswurf. Professioneller Einsatz in härtestem Beton, unterschiedlichem Mauerwerk und Naturstein bis hin zu Granit.

**Ziegelbohrer für Hochlochziegel**

Hochleistungsbohrer für Hochlochziegel. Optimale Schnittkraft im Einsatz ohne Schlagfunktion. Der Lochdurchmesser wird exakt gleich und regelmäßig in allen Außen- und Zwischenwänden des Ziegels.

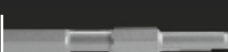
**Bohrer für die Fenstermontage/Fensterbau-Bohrer**

3-Schneider speziell für die Tür- und Fenstermontage. Mit der speziellen Geometrie aus kegelförmigem und zylindrischem Schaft hält er der meist unvermeidbaren Biegung bei Bohrungen in der Fenstermontage stand, ohne zu brechen.

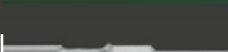
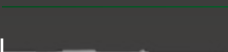
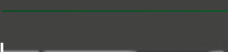
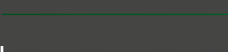
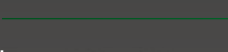
	SDS-plus runder Schaft	155 – 156
	SDS-plus mit Sechskant	157
	SDS-max (TE-Y Hilti)	158 – 160
	SDS-top (TE-T Hilti)	161
	Ø 12 x 40 mm	162
	Ø 17 mm, Ø 13 x 45 mm	163
	Ø 19 mm mit Aussparung, Ø 16,5 x 35 mm mit Rille für Staubschutzkappe	164
	Ø 19 mm mit Aussparung mit Rille für Staubschutzkappe	165
	Ø 19 x 82 mm	166
	Ø 20,5 mm, Ø 16 x 45 mm	167
	Ø 17 mm, Ø 13 x 75 mm	168
	Ø 21 mm, mit Aussparung, Ø 19 x 65 mm	169
	Ø 22 mm, mit 6 Nuten (TE-S Hilti)	170
	Ø 28 mm, mit Aussparung	171
	Ø 30 mm, mit Aussparung, Ø 24 x 55 mm	172

Alle Einsteckwerkzeuge von SOLIDA sind nur für ihren bestimmungsgemäßen Gebrauch in den mit den passenden Werkzeugaufnahmen versehenen Maschinen bestimmt und geeignet. Darüber hinaus sind die Bedienungsanleitungen und Sicherheitshinweise der Maschinenhersteller zu beachten. Für diesbezüglichen Fehlgebrauch übernimmt SOLIDA keine Haftung.



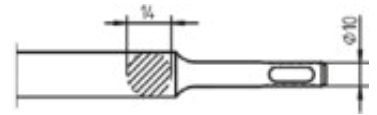

**SDS-plus
runder Schaft**

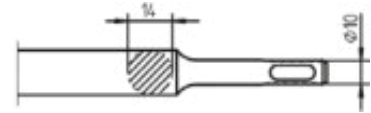

	Spitzmeissel		–	250	0,25	4171 008 025	
	Spitzmeissel mit Sprengwirkung		–	250	0,23	4171 349 025	
	Flachmeissel		20	250	0,25	4171 013 025	
	Spatmeissel		40	200	0,23	4171 043 020	
	Spatmeissel gebogen		40	200	0,23	4171 044 020	
	Fliesenmeissel		40	260	0,27	4171 244 026	
	Breitmeissel		60	250	0,32	4171 057 025	
	Breitmeissel gebogen		60	250	0,32	4171 058 025	
	Hohlmeissel		22	240	0,23	4171 217 024	
	Uni-Kanalmeissel		22	250	0,37	4171 229 025	
	Zahneisen mit Hartmetall		10 x 32	130	0,12	4171 236 013	
	Zahneisen mit Hartmetall		10 x 32	200	0,2	4171 235 020	
	Stechbeitel		20	175	0,12	4171 521 017	
			30	175	0,15	4171 525 017	







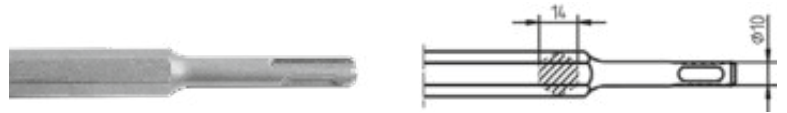

**SDS-plus
runder Schaft**



					solida - Nr.
		100	250	0,37	4171 137 025
		100	120	0,2	94 4171 1370













**SDS-plus
mit Sechskant**



					solida - Nr.
		-	250	0,31	4171 010 025
		20	250	0,31	4171 011 025
		40	200	0,31	4171 022 020
		22	240	0,31	4171 215 024

**SDS-max
(TE-Y Hilti)**



						solida - Nr.
	Spitzmeissel		-	280	0,48	4176 010 028
			-	400	0,72	4176 010 040
			-	600	1,1	4176 010 060
			-	800	1,5	4176 010 080
			-	1000	1,9	4176 010 100
	Spitzmeissel mit Sprengwirkung		-	400	0,7	4176 349 040
	Flachmeissel		24	280	0,48	4176 011 028
			24	400	0,72	4176 011 040
			24	600	1,1	4176 011 060
			24	800	1,5	4176 011 080
			24	1000	1,9	4176 011 100
	Breitmeissel		50	360	0,7	4176 035 036
	Breitmeissel		80	300	0,65	4176 055 030
	Breitmeissel gebogen		50	300	0,6	4176 029 030
	Breitmeissel gebogen		80	300	0,65	4176 056 030
	Breitmeissel		115	350	1	4176 065 035







**SDS-max
(TE-Y Hilti)**



						solida - Nr.
	Asphaltspaten		90	400	1,2	4176 107 040
	Hohlmeissel		26	300	0,45	4176 214 030
	Kanalmeissel		32	300	0,6	4176 226 030
	Uni-Kanalmeissel		35	380	0,9	4176 228 038
	Schaufelspaten		115	400	1,4	4176 115 040
	Schaufelspaten		110	400	1,2	4176 194 040
	Zahneisen mit Hartmetall		10 x 38	280	0,45	4176 240 028
	Zahneisen ohne Hartmetall		7 x 38	280	0,5	4176 233 028
	Stocker 16 Zähne		45 x 45	240	1	4176 631 024
	Erdnageleintreiber		Ø 13	260	0,6	4176 664 026
			Ø 16,5	260	0,6	4176 665 026
			Ø 19	260	0,7	4176 666 026
	Spachtelmeissel		152	635	2,23	4176 135 063















**SDS-max
(TE-Y Hilti)**



					solida - Nr.
		152	180	1,1	94 4176 1350
		Ø 60	350	2,3	4176 807 035
		120 x 120	320	2,5	4176 652 032
		150 x 150	320	3,7	4176 653 032









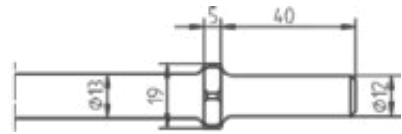



**SDS-top
(TE-T Hilti)**



						solida - Nr.
	Spitzmeissel		–	270	0,28	4182 010 027
	Flachmeissel		20	270	0,28	4182 011 027
	Spatmeissel		40	250	0,3	4182 043 025
	Spatmeissel gebogen		40	250	0,3	4182 044 025
	Breitmeissel		60	250	0,34	4182 057 025
	Breitmeissel gebogen		60	250	0,34	4182 058 025
	Kanalmeissel		22	250	0,35	4182 216 025
	Hohlmeissel		22	250	0,35	4182 217 025
	Uni-Kanalmeissel		22	250	0,4	4182 229 025
	Zahneisen mit Hartmetall		10 x 32	220	0,22	4182 236 022









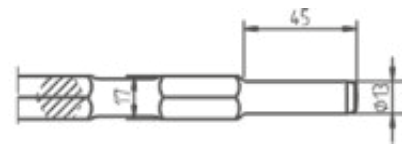





Einsteckende
Ø 12 x 40 mm

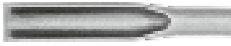

					solida - Nr.
		-	235	0,25	4166 008 024
		20	235	0,25	4166 013 024
		40	185	0,23	4166 043 019
		50	190	0,23	4166 020 019
		40	185	0,23	4166 044 019
		50	190	0,23	4166 021 019
		22	250	0,34	4166 216 025

Einsteckende
□ 17 mm, Ø 13 x 45 mm



					 kg	solida - Nr.
	Spitzmeissel		-	280	0,45	4255 010 028
			-	450	0,77	4255 010 045
	Flachmeissel		24	280	0,45	4255 011 028
			24	450	0,77	4255 011 045
	Spatmeissel		45	280	0,55	4255 028 028
	Hohlmeissel		26	300	0,53	4255 214 030
	Uni-Kanalmeissel		35	380	1	4255 228 038
	Rammglocke		Ø 60	350	2,5	4255 807 035
	Stampfwerkzeug		120 x 120	320	2,3	4255 652 032
			150 x 150	320	3,5	4255 653 032

Einsteckende
 □ 19 mm mit Aussparung,
 Ø 16,5 x 35 mm
 mit Rille für Staubschutzkappe

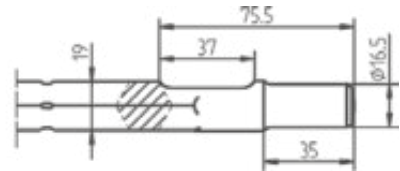

					solida - Nr.	
		–	300	0,65	4152 010 030	
		–	400	0,9	4152 010 040	
		–	450	1	4152 010 045	
			24	300	0,65	4152 011 030
			24	400	0,9	4152 011 040
			24	450	1	4152 011 045
			50	300	0,82	4152 020 030
			80	300	1	4152 055 030
			110	400	1,29	4152 195 040
			Ø 60	350	2,5	4152 807 035
			120 x 120	320	2,4	4152 652 032
			150 x 150	320	3,6	4152 653 032



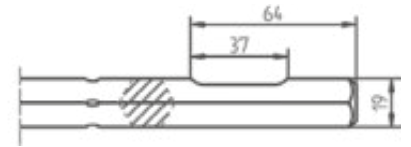





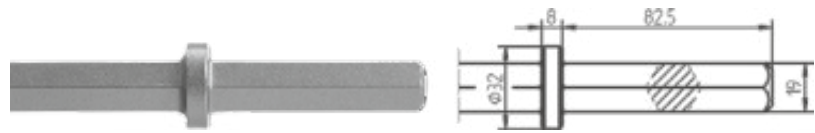







Einsteckende
 ○ 19 mm mit Aussparung
 mit Rille für Staubschutzkappe



						solida - Nr.
	Spitzmeissel		-	400	0,9	4153 010 040
			-	600	1,36	4153 010 060
	Flachmeissel		24	400	0,9	4153 011 040
			24	600	1,36	4153 011 060
	Breitmeissel		60	300	0,85	4153 040 030
			60	450	1,2	4153 040 045
	Breitmeissel		140	350	1,5	4153 070 035
	Hohlmeissel		22	300	0,64	4153 211 030
	Uni-Kanalmeissel		35	380	1	4153 228 038
	Rammglocke		Ø 60	350	2,5	4153 807 035
	Stampfwerkzeug		120 x 120	320	2,4	4153 652 032
			150 x 150	320	3,6	4153 653 032









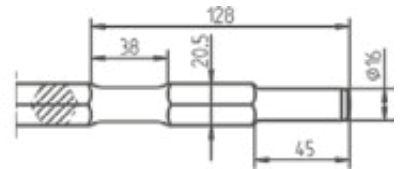



Einsteckende
 ⌀ 19 x 82 mm



					solida - Nr.
		-	280	0,8	4112 010 028
		-	480	1,4	4112 010 048
		24	280	0,8	4112 011 028
		24	480	1,4	4112 011 048
		70	160	0,7	4112 041 016
		80	300	1,2	4112 053 030
		100	300	1,6	4112 095 030
		Ø 60	270	2,6	4112 807 027
		120 x 120	240	2,5	4112 652 024
		150 x 150	240	3,7	4112 653 024







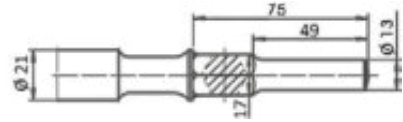

Einsteckende
□ 20,5 mm, Ø 16 x 45 mm



				 kg	solida - Nr.
		–	320	0,74	4257 010 032
		–	450	1,11	4257 010 045
		–	600	1,54	4257 010 060
		24	320	0,74	4257 011 032
		24	450	1,11	4257 011 045
		24	600	1,54	4257 011 060
		70	320	1	4257 041 032
		Ø 60	350	2,6	4257 807 035
		120 x 120	320	2,5	4257 652 032
		150 x 150	320	3,7	4257 653 032

Einsteckende
 \square 17 mm, \varnothing 13 x 75 mm



						
						solida - Nr.
	Spitzmeissel	-	280	0,55	4258 010 028	
	Flachmeissel		21	280	0,56	4258 011 028



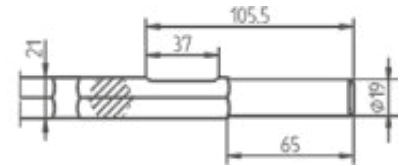









Einsteckende
 Ø 21 mm, mit Aussparung
 Ø 19 x 65 mm



					kg	solida - Nr.
	Spitzmeissel		-	300	0,72	4151 010 030
			-	380	0,94	4151 010 038
			-	460	1,2	4151 010 046
			-	600	1,56	4151 010 060
	Flachmeissel		24	300	0,72	4151 011 030
			24	380	0,94	4151 011 038
			24	460	1,2	4151 011 046
			24	600	1,56	4151 011 060
	Breitmeissel		50	300	0,75	4151 020 030
	Breitmeissel		75	300	0,9	4151 050 030
	Breitmeissel		140	310	1,4	4151 070 031
	Flachspaten		100	450	2,1	4151 100 045
	Uni-Kanalmeissel		35	380	1	4151 228 038
	Rammglocke		Ø 60	350	2,6	4151 807 035
	Stampfwerkzeug		120 x 120	320	2,5	4151 652 032
			150 x 150	320	3,7	4151 653 032

Einsteckende (TE-S Hilti)
 22 mm, mit 6 Nuten



							
	Spitzmeissel	-	360	0,95	4186 010 036		
		-	500	1,45	4186 010 050		
		-	700	2,16	4186 010 070		
	Flachmeissel	28	360	0,98	4186 011 036		
		28	500	1,48	4186 011 050		
		28	700	2,19	4186 011 070		
	Breitmeissel	55	360	1,05	4186 034 036		
	Breitmeissel	80	360	1,33	4186 105 036		
	Rammglocke	Ø 60	350	2,8	4186 807 035		
	Stampfwerkzeug	120 x 120	320	8,6	4186 652 032		
		150 x 150	320	12,5	4186 653 032		

Einsteckende
Ø 28 mm, mit Aussparung

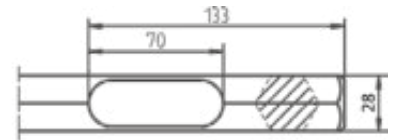

						solida - Nr.
	Spitzmeissel		-	400	1,97	4156 010 040
			-	500	2,45	4156 010 050
	Flachmeissel		32	400	1,97	4156 011 040
			32	500	2,45	4156 011 050
	Breitmeissel		80	400	2,4	4156 101 040
	Flachspaten		125	400	2,8	4156 125 040
	Rammglocke		Ø 60	440	4,6	4156 807 044
			Ø 80	440	5,3	4156 808 044
	Stampfwerkzeug		150 x 150	410	8,6	4156 655 041
			200 x 200	410	12,5	4156 656 041

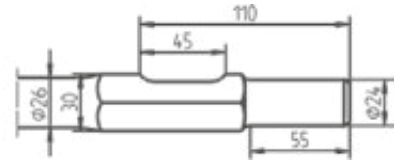

Einsteckende
 □ 30 mm, mit Aussparung
 Ø 24 x 55 mm



					solida - Nr.	
		–	400	1,65	4164 010 040	
		–	700	2,9	4164 010 070	
		–	1000	4	4164 010 100	
			32	400	1,65	4164 011 040
	Flachmeissel HM1400, GSH16–30		32	400	1,65	4164 012 040
	Flachmeissel		32	700	2,9	4164 011 070
			32	1000	4	4164 011 100
			75	400	2,4	4164 048 040
	Breitmeissel HM1400, GSH16–30		75	400	2,4	4164 049 040
			125	400	2,8	4164 125 040
	Spaten HM1400, GSH16–30		125	400	2,8	4164 126 040
			115	400	2,7	4164 189 040
	Asphaltschneider HM1400, GSH16–30		115	400	2,7	4164 187 040
			Ø 60	410	4,1	4164 807 041
			Ø 80	410	4,8	4164 808 041
			150 x 150	380	8,1	4164 655 038
			200 x 200	380	12	4164 656 038

electrotools

LEGENDE

- ∅ = Durchmesser Bohrkopf
 = Gesamtlänge
 = Arbeitslänge
 = Gewicht
_solida - Nr. = Bestellnummer

-  = geeignet für Beton, armiert
 = geeignet für Hohlblock
 = geeignet für Beton
 = geeignet für Backstein
 = geeignet für Stein
 = geeignet für Granit
 = geeignet für Hochlochziegel
 = Ohne Schlag



solida®
GERMANY





**SDS-plus
Hammerbohrer 2S**



∅ = 10 mm



∅			kg	solida - Nr.
5	100	160	0,040	PA050016
5,5	100	160	0,042	PA055016
6	50	110	0,037	PA060011
6	100	160	0,045	PA060016
6	150	210	0,053	PA060021
7	100	160	0,049	PA070016
8	50	110	0,044	PA080011
8	100	160	0,054	PA080016
8	150	210	0,069	PA080021
8	200	260	0,077	PA080026
8	250	310	0,090	PA080031
10	100	160	0,069	PA100016
10	150	210	0,091	PA100021
10	200	260	0,101	PA100026
10	250	310	0,120	PA100031
12	100	160	0,090	PA120016
12	150	210	0,113	PA120021
12	200	260	0,138	PA120026
12	250	310	0,168	PA120031





**SDS-plus
Hammerbohrer 2S**



∅ = 10 mm



∅			kg	_solida - Nr.
14	150	210	0,131	PA140021
14	200	260	0,167	PA140026
14	250	310	0,200	PA140031
14	400	460	0,250	PA140046
16	100	160	0,130	PA160016
16	150	210	0,170	PA160021
16	200	260	0,208	PA160026
16	250	310	0,239	PA160031
16	400	460	0,352	PA160046
18	250	310	0,315	PA180031
18	400	460	0,413	PA180046
20	250	310	0,399	PA200031
20	400	460	0,530	PA200046
22	400	460	0,640	PA220046
24	400	460	0,735	PA240046
26	400	460	0,867	PA260046





**SDS-plus
Hammerbohrer 3S**



∅ = 10 mm



∅			kg	solida - Nr.
5	100	160	0,040	PB050016
6	50	110	0,037	PB060011
6	100	160	0,045	PB060016
6	150	210	0,053	PB060021
6	200	260	0,063	PB060026
6,5	150	210	0,058	PB065021
8	50	110	0,044	PB080011
8	100	160	0,056	PB080016
8	150	210	0,069	PB080021
8	200	260	0,077	PB080026
8	250	310	0,090	PB080031
8	400	460	0,126	PB080046
10	100	160	0,069	PB100016
10	150	210	0,091	PB100021
10	200	260	0,101	PB100026
10	250	310	0,120	PB100031
10	400	460	0,170	PB100046
12	100	160	0,088	PB120016
12	150	210	0,112	PB120021
12	200	260	0,138	PB120026

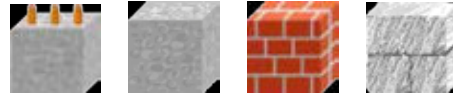



**SDS-plus
Hammerbohrer 3S**



∅ = 10 mm



∅			kg	_solida - Nr.
12	250	310	0,161	PB120031
12	400	460	0,238	PB120046
14	100	160	0,103	PB140016
14	150	210	0,131	PB140021
14	200	260	0,167	PB140026
14	250	310	0,200	PB140031
14	400	460	0,292	PB140046
16	150	210	0,170	PB160021
16	200	260	0,208	PB160026
16	250	310	0,218	PB160031
16	400	460	0,321	PB160046
18	200	260	0,283	PB180026
18	250	310	0,315	PB180031
20	200	260	0,295	PB200026
20	250	310	0,351	PB200031



**SDS-plus
Hochlochziegelbohrer**



∅ = 10 mm







∅			kg	solida - Nr.
6	200	260	0,065	PZ060026
8	200	260	0,091	PZ080026
8	400	460	0,190	PZ080046
10	200	260	0,125	PZ100026
10	400	460	0,232	PZ100046
12	200	260	0,161	PZ120026
14	200	260	0,180	PZ140026
15	200	260	0,245	PZ150026
16	200	260	0,245	PZ160026



**SDS-plus
Fensterbau-Bohrer**



∅ = 10 mm

	∅			kg	_solida - Nr.
 	6	150	210	0,052	PF060021
	6	200	260	0,063	PF060026
	6,5	150	210	0,060	PF065021
	6,5	200	260	0,069	PF065026
	6,5	250	310	0,082	PF065031

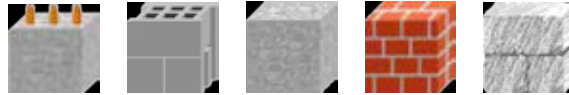



**SDS-max
Hammerbohrer 3S**



∅ = 18 mm



∅			kg	solida - Nr.
12	200	340	0,382	MB120034
12	400	540	0,477	MB120054
14	200	340	0,403	MB140034
14	400	540	0,593	MB140054
15	200	340	0,441	MB150034
15	400	540	0,561	MB150054





**SDS-max
Hammerbohrer 6S**



∅ = 18 mm



∅			kg	_solida - Nr.
16	200	340	0,441	MC160034
16	400	540	0,593	MC160054
18	200	340	0,501	MC180034
18	400	540	0,718	MC180054
20	200	340	0,548	MC200034
20	400	540	0,819	MC200054
22	200	340	0,600	MC220034
22	400	540	0,934	MC220054
24	200	340	0,669	MC240034
24	400	540	1,050	MC240054
25	400	540	1,144	MC250054
28	400	540	1,334	MC280054
30	400	540	1,472	MC300054
32	400	540	1,382	MC320054



A blank sheet of white paper with horizontal green lines, resembling a notebook page. The lines are evenly spaced and extend across the width of the page. The paper has rounded corners and is set against a dark grey background.



solida®
GERMANY

www.solida-werk.com

hydraulictools

pneumatictools

electrotools



Beat the hammer

SOLIDA-Werk
Werkzeugtechnik GmbH & Co.
Kommanditgesellschaft
Auf dem Knapp 10
42855 Remscheid
GERMANY

T +49 2191 3715-0
F +49 2191 3715-20
sales@solida-werk.com

www.solida-werk.com